

IEEE Copyright Statement:

Copyright © 2007 IEEE. Reprinted from IEEE Special Issue on “Modeling, Identification, and Control of Large-Scale Dynamical Systems,” Simon Haykin and Eric Moulines, Guest Editors, Vol. 95, No. 5, May 2007.

This material is posted here with permission of the IEEE. Such permission of the IEEE does not in any way imply IEEE endorsement of any of Carnegie Mellon University's products or services. Internal or personal use of this material is permitted. However, permission to reprint/republish this material for advertising or promotional purposes or for creating new collective works for resale or redistribution must be obtained from the IEEE by writing to pubs-permissions@ieee.org.

By choosing to view this document, you agree to all provisions of the copyright laws protecting it.

From Hierarchical to Open Access Electric Power Systems

To operate large power grids under stress, model-guided decisions based on economic and policy feed-forward and feedback signals as well as technical signals may be needed.

By MARIJA D. ILIĆ, *Fellow IEEE*

ABSTRACT | In this paper the modeling, monitoring, and control of electric power systems are presented from the point of view of large-scale dynamic systems. First a summary of current hierarchical operations is given, together with an assessment of the underlying assumptions. Next, the challenge of operating electric power systems over very broad ranges of system conditions is presented as an open sensing, estimation, and control problem. The latter part of this paper is motivated by fundamental technological and organizational changes. These are requiring a shift from hierarchical to multilayered open access modeling, monitoring, and control paradigms for large complex electric power systems. A vision of a novel information-based multilayered Dynamic Energy Control Protocols (DECPS) framework for facilitating evolution into open access just-in-time (JIT) and just-in-place (JIP) electricity services of the future is presented.

KEYWORDS | Corrective control; differentiated quality of service (QoS); hierarchical control; just-in-place (JIP) electricity service; just-in-time (JIT) electricity service; model structure; multiscale dynamics; preventive control; state-space models of electric power systems

I. INTRODUCTION

Electric power systems are generally viewed as systems designed long ago with standardized equipment and well-understood functionality. A general perception is that there is very little opportunity for improvements relative to the innovations taking place in some other systems. In

this paper we suggest that it is actually essential to innovate since the system is expected to serve electricity according to qualitatively different paradigms than those for which it was designed. As a matter of fact, major challenges and opportunities arise from the need to utilize new technologies, such as sensing, communications, computing, and control in order to meet newly evolving system requirements. Their systematic deployment for well-understood performance challenges the state-of-the-art in large-scale dynamic systems. We attempt to substantiate these statements with the contents of this paper.

We start by emphasizing the systems nature of the problem and the underlying engineering principles. In order to identify new needs and explore potential benefits from deploying less traditional technologies, it is essential first to understand the systems aspects of current operating and planning paradigms of large-scale electric power grids. One way to proceed is to consider the basic features of their architecture. Such understanding is critical for posing the problem as a complex engineering system with well-defined performance objectives, as well as for understanding how these objectives are attempted in today's industry. This approach, furthermore, helps to identify when the system may fail to perform. Section II is written with this concern in mind. Section III summarizes the overall performance objectives of today's industry. Next, in Section IV, a general dynamic model is presented based on the local characteristics of system components and network constraints. Section V follows with the definition of an underlying structure-based model essential for conceptualizing principles of today's hierarchical monitoring and control. A systems approach is taken here to capture the complexity of the dynamics ranging over vast time horizons in response to the drivers, such as exogenous inputs and disturbances, short-term feed-forward and feedback signals, and new candidate technologies. A brief summary highlights frequently used dynamic models and

Manuscript received September 1, 2005; revised February 1, 2006. This work was supported in part by the U.S. National Science Foundation under Grant CNS-0428404. The author is with the Electrical & Computer Engineering (ECE) and Engineering & Public Policy (EPP), Carnegie-Mellon University, Pittsburgh, PA 15213 USA (e-mail: milic@ece.cmu.edu; milic@andrew.cmu.edu; ilic@mit.edu).

Digital Object Identifier: 10.1109/JPROC.2007.894711

the assumptions implied in these models. In preparation for discussing the potential of novel technologies, we review current decision making tools and the computer architectures underlying traditional supervisory control and data acquisition systems (SCADAs). A structure-based modeling from Section V is next used in Section VI to formalize today's hierarchical monitoring and control principles, such as the multiplicity of time scales, separable spatial layers, and primary, secondary, and tertiary feedback control in electric power systems.

Once the basic principles of today's monitoring and control are formalized, the rest of the paper is devoted to two major challenges. First, in Section VII, the challenges seen in operating electric power systems under stress are described. This is followed by an assessment of the effects of measurement, estimation, and communications schemes on the types of models needed in order to attempt at least partial automation during abnormal operation. Modeling is an important aspect of the changing industry; in the past much of the modeling and analysis was done assuming hierarchical data structures. The process of mapping data into used and useful information is greatly dependent on the measurement structure in place. We further recognize that system control can be vastly different depending on the types, location, and logic of sensors and actuators placed on the system. Basic controllability and observability characteristics of the power grid depend to a very significant degree on the sensors and actuators placed throughout the complex power grid, as well as on the performance objectives of various power grid users and the grid operators and designers. The structure-based modeling framework used in the first part of the paper is suggested as a possible means of identifying the minimum information required to monitor and control power grids during abnormal operating conditions when the hierarchical models of today are not adequate. Related challenges and opportunities are summarized for the changing electric power industry in Section VIII. The changes are technological, organizational, and more broadly, structural. We highlight that representing interactions between decision makers in the changing industry could be viewed as an outgrowth of the structure-based framework used in the first part of the paper. Questions concerning information exchange between predominantly distributed decision makers are posed by further generalizing the notions of interaction variables. Much the same way as in today's industry, interaction variables play a fundamental role in defining the interplay between the various industry layers. What is new is that the boundaries of the layers are no longer fixed, and could vary over time as the objectives vary. Moreover, the interaction variables are generally heterogeneous, and could be technical and/or economic/policy in nature.

While one of the prime objectives of automated power grid control is to keep its operations stable in face of fast

hard-to-predict disturbances, it is important to view the objectives of decision making for a complex power grid as a more general problem. In particular, future electricity service requirements will be more widely distributed across different classes of users and providers. This varied distribution leads to differentiated reliability services, which are qualitatively different than in the hierarchically managed industry. The emphasis is on the key role of modeling, monitoring, and control for facilitating penetration of the most promising technologies to implement differentiated quality of service (QoS). We present our novel idea of incorporating economic and policy feed-forward and feedback signals, in addition to the technical signals, and designing Dynamic Energy Control Protocols (DECPs) [41]; such DECPs are needed for the distributed decision makers with their primal variables to internalize the effects of others by exchanging the dual variables in an iterative way, both with respect to time and organizational boundaries. We illustrate these performance objectives for several key evolving industry architectures and candidate technologies. Only a more systematic view of power grid dynamics will lend itself to assessing the potential value of various power electronic-switched technologies, generally referred to as flexible ac transmission systems (FACTS), fast measurement and processing sensors such as phasor measurement units (PMUs), as well as demand response technologies, including dynamic pricing, and the new distributed generation (DG). Finally, in Section IX we close by suggesting several open research and development problems. Since the future industry is likely to rely increasingly on just-in-time (JIT) and just-in-place (JIP) services, frameworks for their implementation present a major challenge to the present state of the art in large-scale dynamic systems.

II. BASIC PHYSICAL ARCHITECTURE OF TODAY'S ELECTRIC POWER NETWORKS

Electric power systems are very large-scale electric power networks interconnecting sources of electric power (generators) to the points of power consumption (loads). The interconnection has evolved over time to meet the needs of an ever growing demand for electricity. Several key drivers have shaped the basic topology of today's systems, such as: 1) large power plants, often remote from load centers; 2) utilities supplying their customers without depending much on the neighboring utilities; and 3) utilities interconnecting for reliability reasons, to help each other during major equipment failures.

Consequently, the electric power grid has several voltage levels, converted from one to the other by step-up and step-down transformers [91]. This has led to an extra-high-voltage (EHV) meshed transmission backbone network, and distribution (local) lower voltage networks closer to the power consumers. Local networks are typically radial in structure. Shown in Fig. 1 is a sketch of

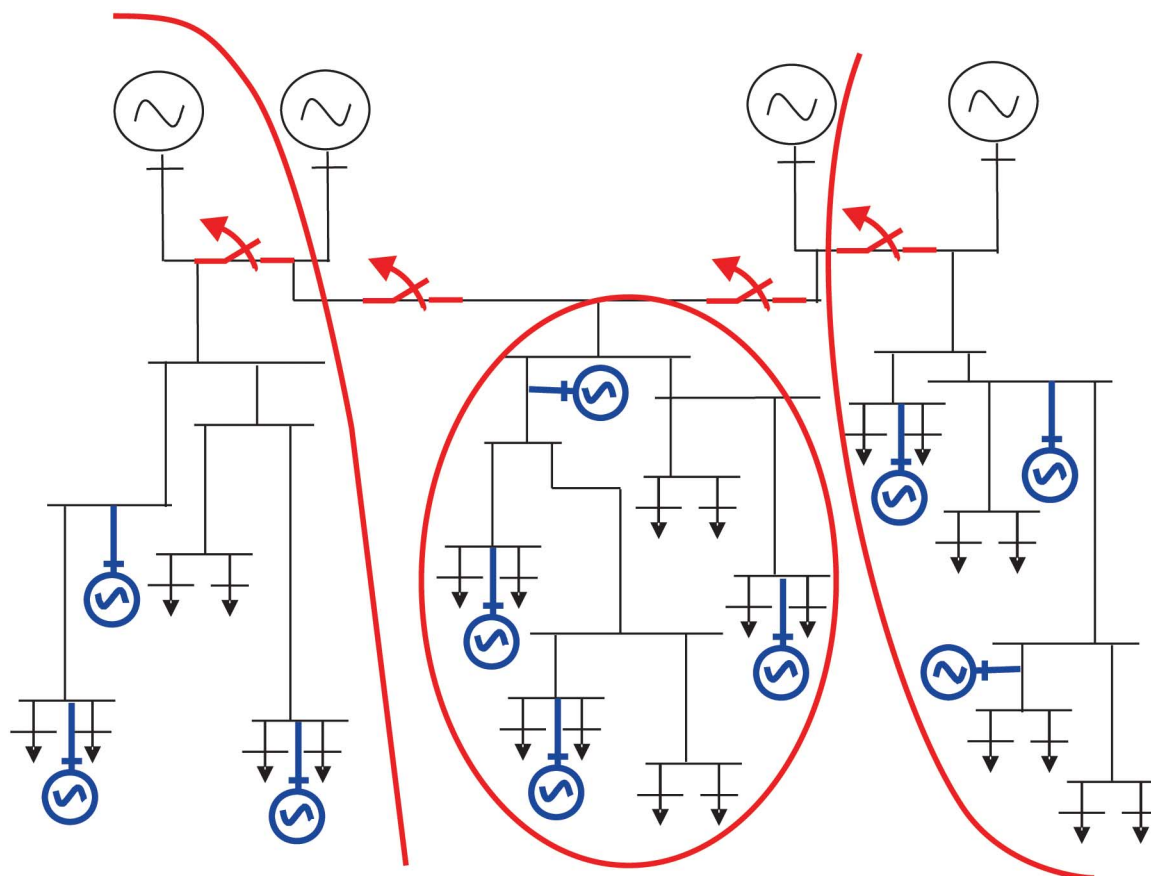

Fig. 1. Current electric power architectures.

this inherently hierarchical structure with respect to voltage levels present in a typical electric power interconnection, such as the Eastern Interconnection in the United States. Generators, denoted by circles with wiggles, are connected to the subtransmission or lower voltage transmission portion of the interconnection. They are further connected via step-up transformers to the EHV transmission network so the power is transferred long distance at as high voltage as possible to reduce transmission losses. Closer to the end users are placed step-down transformers connecting the EHV network to the substations and transforming back to lower voltage levels to supply consumers down to the residential houses.

This physical network is structured both vertically and horizontally with respect to the operating objectives. To start with, a large regional interconnection, such as the one in the eastern United States, is horizontally structured into many utilities with their own objectives of supplying customers with reliable and economic electricity. Red circles in Fig. 1 represent boundaries of these utilities. Each utility is furthermore vertically integrated into a single owner and operator (control area) of its own

generation, typically located in the same geographical area, and the transmission and distribution networks all the way to the customers. The EHV and HV subnetworks utility subnetworks are meshed and sparse, while the local networks are radial during normal operations. Local networks often have normally open switches (NOSs) which close to supply customers from different power sources during equipment failures. There exist also fairly weak connections at the EHV and HV levels between various utilities for reliable service during large equipment failures. It has generally been more economic to rely on neighboring utilities for sending power via these tie-lines at times when utilities lose some of their own power.

III. PLANNING AND OPERATING PERFORMANCE OBJECTIVES OF TODAY'S ELECTRIC POWER SYSTEMS

The overall objective of traditional electric power system is simple: minimizing total cost subject to reliability constraints. The implementation of this objective is complex when viewed as a single problem of decision making for very large-scale dynamic systems. The industry attempts to

optimize the expected costs of serving customers subject to a variety of constraints, such as system dynamics and many input and output constraints. This is done for hard-to-forecast demand characteristics of the end users and the uncertain system equipment status. Moreover, the ownership of a typical electric power grid is distributed among different utilities with their own subobjectives making the objectives of the entire interconnection even more difficult to meet.

It is striking that the existing and changing structures of electric power grids have evolved with very little reliance on formal systems control principles. Instead, various assumptions have made the design and operations manageable by the engineers themselves, without their always having to rely on very detailed modeling and analysis. This creates an interesting challenge in its own right, as one wishes to explore the potential of more systematic sensing, communications, computing, and control for predictable performance and more diverse electricity services of the future. Essentially, it becomes necessary to take a step back, pose the problem, and understand often implied assumptions made in today's operating and planning industry practices. A large portion of this paper is devoted to these tasks.

Possibly one of the most difficult challenges in developing effective software tools for the electric power industry is thinking about the problem as a stochastic dynamic problem evolving at vastly different rates. The very question of conditions under which the single problem can be decomposed into simpler subproblems when the objective is long-term optimization under uncertainties subject to short-term operating constraints makes this problem a singularly perturbed stochastic control problem [6], [48]. A possible approach to work one's way through this very difficult problem is to decompose the problem into:

- functions which require feed-forward scheduling and
- functions which require feedback design.

This separation makes it possible to review today's practices and, ultimately, to assess potential problems and opportunities for improving.

A. Feed-Forward Decision Making in Today's Industry

Consider an electric power network with n nodes whose net generation/demand is controllable and the remaining nd nodes whose power injections are uncertain load demands.

Historically, utilities have viewed load demand as uncertain system input; various forecasting methods have been developed for forecasting hourly, daily, weekly, seasonal, and to a lesser extent, annual cycles in load demand changes. Power systems operations and planning have been carried out with the main objective of supplying this forecasted demand. Decisions concerning investments

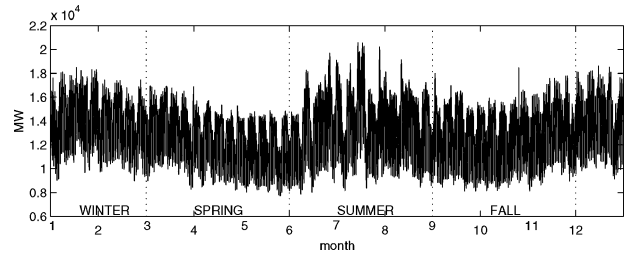

Fig. 2. Total electricity demand for 1997 in the NEPOOL area.

in new generation and transmission, and their scheduling, can be formulated as a control problem by representing the uncontrolled portion of the load as an uncertain disturbance $P_L(t)$, and the controllable portion of the load demand (including its responsiveness to change in the price of electricity) as a negative, controllable generation [89].¹ The representative load demand characterization and its periodicities are shown in Fig. 2 [18].

The corresponding cumulative probability (load duration curve) is shown in Fig. 3. Based on these figures, one can observe at least three periodicities relevant for our problem formulation. Depending on the optimization period T of interest, one can model demand as a diffusion-type process characterized with different load duration curves (probability distribution curves).

For instance, if one is interested in the short run demand, e.g., hourly load fluctuation P_L^{hour} , the load demand model could be represented as a diffusion process of the form

$$dP_L^{\text{hour}} = \beta(\tau, P_L^{\text{hour}})d\tau + \sigma dW_\tau. \quad (1)$$

Similarly, the diffusion model for seasonal demand could be modeled as

$$dP_L^{\text{season}} = \frac{1}{\varepsilon}\beta\left(\frac{\tau}{\varepsilon}, P_L^{\text{season}}\right)d\tau + \frac{1}{\varepsilon}\sigma dW_\tau \quad (2)$$

where $\varepsilon = 1/2160$.

The coordinated scheduling and planning problem is a combined problem of short-term least-cost generation scheduling and investment in new generation and transmission to balance uncertain load demand deviations ranging from hourly through seasonal and long-term. If one were to formalize the objectives of operations and

¹This amounts to replacing the social welfare criterion with controllable cost; it is straightforward to include price-elastic demand as an active decision variable if desired [85].

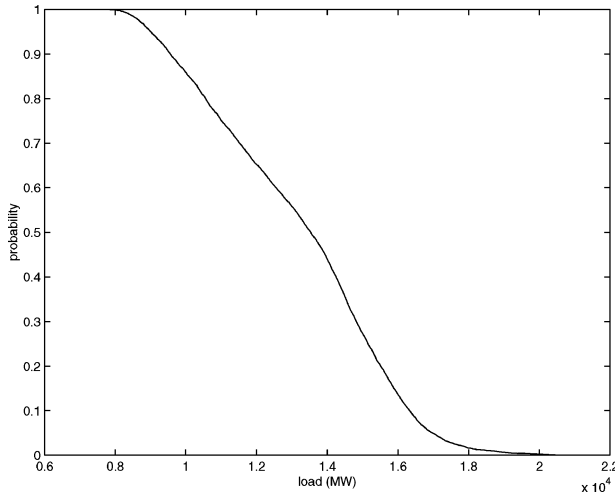

Fig. 3. The load duration curve constructed from NEPOOL data of 1997.

planning as a single decision making problem this would become a very high order stochastic dynamic optimization problem with a possible mathematical formulation as follows [89]:

$$\min_{I_i^T, I_i^G, P_i} \mathcal{E} \left\{ \sum_i \int_{t_0}^T e^{-\rho t} (c_i(t, P_i(t))) dt + \sum_i \int_{t_0}^T e^{-\rho t} (C_i^G(K_i^G(t), I_i^G(t), t)) dt + \sum_l \int_{t_0}^T e^{-\rho t} C_l^T(K_l^T(t), I_l^T(t), t) dt \right\} \quad (3)$$

subject to:

$$\frac{dK_l^T}{dt} = I_l^T(t) \quad (4)$$

$$\frac{dK_i^G}{dt} = I_i^G(t) \quad (5)$$

$$I_l^T(t) \geq 0 \quad (6)$$

$$I_i^G \geq 0 \quad (7)$$

$$F_l(P_G(t), P_L(t)) \leq K_l^T \quad : \mu_l(t) \quad (8)$$

$$P_i(t) \leq K_i^G \quad : \sigma_i(t) \quad (9)$$

$$f_{\text{spot}} \left(\sum_{i=1}^n P_i(t) - \sum_{j=1}^{nd} P_{L_j}(t) \right) = \frac{d\lambda(t)}{dt}. \quad (10)$$

The optimization period T corresponds to the longer of two time intervals over which the generation or transmission

investments are valued. $\lambda(t)$, $K_i^G(t)$, and $K_l^T(t)$ are state variables and represent price of electricity, generation, and transmission capacity, respectively. The control variables are the rate of investment in transmission capacity $I_l^T(t)$, the rate of investment in generation capacities $I_i^G(t)$, and the injection of power at each node $P_i = P_G(t) - P_L(t)$. The uncertain portion of the load at nodes are disturbance inputs $P_L(t) = [P_{L_1}(t) \cdots P_{L_{nd}}(t)]$. The control is bounded by the set of constraints and the line flows are output variables limited by the network congestion constraints K_l^T . A set of Lagrange multipliers is associated with each set of constraints.

Note: In this formulation, the process of balancing total generation and demand is represented with consideration of the evolving electricity spot markets, and it assumes that the market clears at (economic) equilibrium. In this sense, (10) represents the daily spot market price dynamics. This highly simplified formulation is used to stress the fact that even the daily market-clearing process should be viewed as a dynamic process in composite operations and planning decision-making, see [79].

This problem formulation, in spite of its apparent complexity, captures many well-known tradeoffs relevant for the efficiency of the power industry. First, the discount rate ρ reflects the time value of money. Everything being equal, it is better to spend money now than later. Thus, the investment timing balances the tradeoff between the costs and benefits over time. Second, this formulation shows that different technologies at different locations can be used to produce power. Thus, for a given load duration curve, the ratio between variable costs and capacity costs for each of these generation resources determines the optimal pattern and mix of generation. Third, generation capacity can be substituted for transmission capacity. The main tradeoff between saving on generation costs and investing in transmission capacity is also encapsulated in the problem. The level of transmission capacity is not based on the maximum yearly flow. A tradeoff between the costs of congestion when some line flow limits are reached and the costs of transmission capacity must be considered. Finally, the stochastic formulation reflects the value of dynamic investment under uncertainties [14].

B. Preventive Approach to Managing Uncertain Equipment Status in Today's Industry

In addition to the demand uncertainties, utilities face a tremendous challenge and high costs because of their obligations to serve customers reliably for at least 30 minutes following any single major equipment failure; this is according to the industry guidelines defined by the North American Electric Reliability Council (NERC) [57]. Regional utilities have cooperated when adding new equipment in order to ensure that the region as a whole operates reliably. Time consuming off-line simulations of regional systems are carried out to

simulate the worst case scenarios and to create lists of critical forced outages. Contingencies leading to fast transient instabilities [66], nonrobust response to small deviations in states, parameters, and inputs away from nominal [76], and occurrence of uncontrollable voltage collapse [15] are found and preventive adjustments of thermally limited power transfers are made in order to ensure that during such forced outages no problems of this type take place.

A typical industry approach has been to perform off-line studies to tighten the control and output constraints within which the system would be allowed to operate during normal conditions. The premise is that in case a fault occurs, there will be no dynamic problems and, therefore, no immediate dangers from time-critical problems. Therefore, feed-forward decision making in electric power systems for scheduling available resources assumes that transitions from one to the next schedule are stable.² There are usually several stability-limited interfaces in each region. A combination of local dynamic control and additional constraints on some outputs are used to prevent unstable operation for typical loading conditions and the worst case equipment failures. The results is suboptimal use of system-wide resources during normal conditions so that in case the worst case contingency happens, there is no dynamic problem. The industry refers to this practice as preventive control. Preventive control should be contrasted with corrective control which can result from near real-time solution of the full stochastic dynamic optimization problem. Some forward-looking utilities have begun development of numerical tools for a more corrective approach to ensuring stability in electric power systems during major equipment failures, and are probabilistic in nature [53], [80].

C. Temporal Decomposition of Planning and Scheduling Functions

The coupled scheduling and planning formulation (3)–(10) is obviously complex because it poses operations and planning as a single optimization problem evolving at the same time t . In reality, however, the process of scheduling supply to meet demand in operations typically happens much faster than the rate at which investment decisions are made. This observation is the basis for solving the two subproblems as if they were decoupled. To formally introduce these two subproblems, one can assume that the short-term (weekly, daily, or hourly) decisions are made each week $[W]$, day $[D]$, and hour $[H]$, and investment decisions are made each season $[T_S]$. The problem defined in (3)–(10) can then be restated as an

optimization problem subject to multirate discrete-time processes using techniques introduced in [22], [89]. Even with this temporal decomposition, both short-term generation scheduling and planning problems remain truly stochastic optimization problems, and as such are computationally very challenging. Computer methods used today for such scheduling routinely convert these stochastic problems into static deterministic optimization problems, such as unit commitment methods for turning power plants on and off [7], [64], and constrained economic dispatch methods for adjusting power generation scheduling of units which are on [19]. These methods amount to large-scale nonlinear programming problems which are generally further simplified by being converted into linear programming problems. The most effective methods are based on solving the dual instead of the primal optimization problem resulting in Lagrangian coefficients $\sigma_i(t)$, $\mu_l(t)$ reflecting control and line flow limits, respectively. These are known in the changing industry as shadow prices [67], [85]. Important for the comparison with the open access approach is to observe that these Lagrangian coefficients are obtained by solving a single centralized optimization problem of a bundled generation and transmission provision.

D. Feedback Control Functions in Today's Industry

Given today's preventive control approach to managing large equipment failures by intentionally reducing allowable regions of operation to avoid time-critical events, and relying on human operators to carry out certain predefined procedures, the role of automation has been rather limited in large-scale electric power systems.

One way to summarize feedback control performance objectives is by keeping in mind the basic horizontal organization of a large electric power system into utilities and power pools. Utilities (control areas) are expected to schedule sufficient power to supply the forecast load and the preagreed upon net power exchange with the neighboring utilities.

Hierarchical automation is comprised of a primary (equipment) and secondary (utility) level. At the primary component level, local controllers are tuned to stabilize very fast and small supply/demand imbalances around the forecast demand and the corresponding feed-forward generation schedule. At present they are tuned for what may be considered the worst case scenario and are generally not adaptive to major changes in system conditions. A striking exception to this is the Hydro-Quebec multimodal power system stabilizer (PSS).

At the utility secondary level, control areas are expected to regulate slower, quasi-stationary supply and demand deviations by means of automatic generation control (AGC) [9]. AGC in the United States is the basic mechanism for balancing supply/demand among utilities in an entirely decentralized way. The area control error (ACE) is a weighted sum of frequency deviations in control

²Note that the optimization problem stated above does not have dynamics of the system response as a constraint. This formulation implies that system dynamics are stable as scheduling and investment planning are done. This approach is critically assessed later in Section VII.

area, and deviations in net power flow exchanges, between the control area and its neighbors.

The AGC principle is an effective engineering concept based on the fact that the quasi-static frequency is the same in the entire interconnection [69]; therefore, decentralized feedback implemented by each control area for responding to these frequency deviations contributes to the overall supply/demand balancing in the interconnection. Independently from where the imbalance is created, it can be regulated in response to a single observable variable, system frequency.

At present, the scheduled net tie-line flows are based on agreeing with the neighbors regarding what these should be. The power scheduling for forecast demand is done by each control area scheduling internal power plants to meet the forecast demand in the area and the targeted net flow exchange with the neighboring control areas. However, there are no ways to enforce that the actual tie-line flows are what the schedules attempted, and there is consequently so-called inadvertent energy exchange (IEE) between each control area and the rest of the system. The IEE is a combination of actual tie-line flows deviating from the scheduled tie-line flows and the cumulative fast deviations of tie-line flows from the schedules. Cumulative frequency deviations are controlled by means of time-correction-error control at one power plant in the entire interconnection [73].

We stress here that most of the operating practices are defined and standardized to a large extent for meeting the real power and frequency criteria. The operating and control practices for voltage and reactive power scheduling and control vary largely with the utility practice, much more so in the United States and less so in some countries in Europe [8], [33]. Coordination of real and reactive power scheduling and control practices remains largely a fundamentally open problem. This is discussed in some detail after the introduction of the necessary models.

E. Hierarchical Information Structure in Today's Industry

At the early stages of electric power network evolution, sensors, controllers, and protection relays were based mainly on local measurements. Their set points were either preprogrammed for the forecast demand, and/or were adjusted by the human operators as the loading varied over time.

After the first major blackouts in the early 1960s, the electric power industry recognized the need for more near real-time monitoring of their systems. Consequently, all major U.S. utilities have built their energy management systems (EMS), also known as the control centers, and have implemented a supporting SCADA for processing data and coordinating commands to manage power generation and delivery within the EHV and HV (bulk) portion of their own electric power system [86].

SCADA is the fundamental monitoring and control architecture at the control area level. Moreover, several regions formed electric power pools to operate and manage several utilities in the same region with their own SCADA systems.

Even to this day, the information structure remains highly hierarchical: each primary controller utilizes its own local measurement only, each control area utilizes measurements in its own utility only and has its own SCADA system. Protection, likewise, is preprogrammed to protect individual pieces of equipment and rarely requires communications [62]. There is no on-line coordination between different regions within a large interconnection. As long as conditions are normal [16], the industry sees no need for system-wide scheduling of resources, nor for region-wide (on-line), nor for interconnection-wide on-line coordination. The control is entirely hierarchical and quite effective. The only major issue during normal conditions is a suboptimal use of regional resources due to decentralization.

Most recently, there has been a considerable recognition of the need for synchronizing fast measurements across wider areas, in particular given major breakthroughs in new cost-effective measurement equipment, such as phasor measurement units (PMUs) and frequency measurement units (FMUs). Industry research is under way for systematic deployment of these sensors and their integration into the existing control design. We discuss later in this paper the relevance of these technologies for automating system operations outside normal regions.

IV. GENERAL DAE MODEL OF TODAY'S ELECTRIC POWER SYSTEMS

The dynamics of a real-world electric power system are extremely complex due to the large number of system components, their variety, and vast network connectivity. In order to introduce the basic dynamic model, we start by viewing it as a large network of an arbitrary topology interconnecting locally controlled components (such as generators and capacitor and inductor banks). In today's ac transmission systems during normal steady-state operations, voltages and currents are sinusoidally varying and are characterized by their magnitudes and phase angles measured relative to the single phase angle which defines time zero.³ The magnitudes and angles are assumed to be either constant or exhibit slow variations relative to 60 cycles during normal system operation. When this assumption is met, power engineers use phasors as the principal symbolic language of power system studies. The

³The network node whose phase angle is zero is often referred to as the slack or swing bus; it is the same node to which a time-error correction control is connected to correct for cumulative deviations in system frequency.

time domain representation of variable (voltage, for illustrative purposes) $v(t)$ is

$$v(t) = V \cos(\omega t + \delta) \quad (11)$$

where V and δ may be time varying. The definition of a phasor transformation \wp is

$$\wp v(t) = V e^{j\delta} = \hat{V} \quad (12)$$

where \hat{V} is a complex-valued vector with magnitude V and angle δ . Many decades of experience with simulating angle transients have shown that such quasi-stationary form phasors give a good approximation in that context. With the emergence of voltage stability as a major concern, together with the increase of power transfer, complexity, and loading levels of the power systems combined with the use of computers, many challenging power engineering problems are moving outside the range of validity of the quasi-stationary assumption and one must be careful when studying emerging behavior, in particular. Moreover, the presence of harmonics created by fast power electronic switching in modern electric power systems requires knowledge of generalized phasor concepts applicable to periodic signals with higher-order harmonics.

The most often-used dynamic power system models for monitoring, estimation, and control are derived assuming that quasi-stationarity is valid. This means that the state variables of interest are the magnitudes and angles of time-varying phasors, such as those of phasor voltages \hat{V} measured across the components and phasor currents \hat{I} into the components. Since the specifications are often in terms of power, the major output variable of interest is power. For this, using phasor language, a conveniently created complex power phasor $\hat{S} = P + jQ$ was introduced; its real part represents the real (average) power P into the component and the imaginary part the reactive (imaginary) power Q into the terminals of the component. Note that all lumped parameter models of components use phasors which assume that carrier frequency ω in (11) remains unchanged. On the other hand, if nodal angles deviate, their corresponding change with time is used as a state variable which is frequency and does vary over time. This inconsistency could be confusing and creates open questions when one attempts to capture highly unusual emerging phenomena in electric power systems [77], [78].

In normal operations the phasor dynamics are the result of different components responding to fast fluctuations around the forecast demand and uncertain system parameters. The components with significant dynamic response are power plants, comprising turbines and generators, and their controllers. Although some classes of loads do not change instantly either, most common

models assume their characterization to be static. Similarly, the time constants of transmission lines are much shorter than those of power plants, and as such are assumed to have instantaneous response.⁴

Local generator controllers are governors controlling mechanical power output deviations P_{mech} in response to the frequency deviations ω_G around the set values ω_G^{ref} by adjusting the turbine valve position a , and excitation systems controlling field voltage deviations e_{fd} in response to the terminal voltage deviations E_G from the set value E_G^{ref} . The relevant output variables on the generator side affecting the transmission network and the loads are real power P_G , reactive power Q_G , frequency ω_G and terminal voltage E_G . The P_L , Q_L , ω_L , E_L are the corresponding variables at the load side. During normal operating conditions, governors and excitation systems respond automatically to the frequency and voltage deviations caused by fast load fluctuations. The turbine-generator sets have their own dynamics of producing P_G and Q_G which combined with the governor and excitation systems control form the closed-loop primary (local) dynamics of the governor-turbine-generator (G-T-G) sets of power plants. The closed loop electromechanical dynamics of a G-T-G set combined with the dynamics of its primary controllers is represented as follows [29, Ch. 3], [66]:

$$\dot{\delta}_G = \omega_G - \omega_G^{\text{ref}} \quad (13)$$

$$\dot{\omega}_G = \frac{1}{J} [P_{\text{mech}} - P_G - D(\omega_G - \omega_G^{\text{ref}})] \quad (14)$$

$$\dot{P}_{\text{mech}} = \frac{1}{T_u} [n(P_{\text{mech}}, a)] \quad (15)$$

$$\dot{a} = \frac{1}{T_g} [m(a, \omega_G^{\text{ref}}, \omega_G)] \quad (16)$$

and the closed-loop electromagnetic dynamics of a generator-excitation system as

$$\begin{aligned} \dot{e}'_q &= \frac{1}{T'_{do}} [-e'_q - (x_d - x'_d)i_d + e_{\text{fd}}] \\ \dot{V}_R &= \frac{1}{T_A} \left[(K_A V_F - \frac{K_A K_F}{T_F} e_{\text{fd}} - V_R - K_A (\Delta E_G)) \right] \\ \dot{e}_{\text{fd}} &= -\frac{1}{T_e} [(K_e + S_e)e_{\text{fd}} + V_R] \\ \dot{V}_F &= \left[-V_F + \frac{K_F}{T_F} e_{\text{fd}} \right]. \end{aligned} \quad (17)$$

⁴Some models capture load dynamics and some even the dynamics of power lines [2]. This generally increases model complexity significantly. As unusual phenomena evolve, it is likely that these models will play an increased role. One of the difficult research questions is deciding when to go beyond the general model summarized in this section.

Here e'_q , is the so-called voltage behind the transient reactance, ΔE_G is the output error, and variables V_F and V_R are internal to the standard IEEE excitation system [17].

Local output variables of all components within the interconnected electric power network are subject to basic Kirchhoff laws; power flows are subject to the first law, and voltages to the second law. Structurally, these laws are expressed as

$$P = Ap \quad (18)$$

$$Q = Aq \quad (19)$$

$$\hat{V} = A^T \hat{E} \quad (20)$$

where A is the network incidence matrix of a directed network graph with elements A_{ij} 1, 0, and -1 denoting that line j is connected to the node i with the line flow out the node, not connected or line flow into the node, respectively [13]. Vectors p and q are real and reactive power flows in transmission lines and are nonlinear functions of network nodal voltages \hat{V} and line parameters based on Ohm's law for predominantly resistive–inductive RL lines

$$\hat{I}_{ij} = \hat{Y}_{ij} \hat{V}_{ij}. \quad (21)$$

Vectors P and Q are nodal real and reactive power injections into each node i . Finally, vector of nodal voltages is $\hat{E} = E^{i\delta}$ and the vector of voltages across transmission lines is \hat{V} . Combining network constraints (18)–(20) with the line characteristic (21) results in nonlinear algebraic equations known as the power flow equations [68]. The power flow equations can be written in a matrix form [29] as

$$\text{diag}(\hat{E}) \hat{Y}_{\text{bus}}^* [\hat{E}_1 \hat{E}_2 \cdots \hat{E}_n]^* T = [\hat{S}_1 \hat{S}_2 \cdots \hat{S}_n]^T \quad (22)$$

where \hat{S}_i represents a phasor of complex power injected into node i . \hat{Y}_{bus}^* represents a complex-conjugate of the bus admittance matrix [13]

$$\hat{Y}_{\text{bus}} = A \hat{Y} A^T \quad (23)$$

where \hat{Y} is a diagonal matrix with its nonzero terms being admittances \hat{Y}_{ij} of individual transmission lines defined in (21). The complex-valued power flow formulation (22) is useful for understanding the structure inherent in electric power networks such as M -matrix properties of RL networks [87], block diagonal dominance of decoupled real power flow linearized equations [32], and tridiagonal block form of the nodal angle sensitivity matrix with respect to disturbances in real power injection [34], [35]. These

properties are essential for supporting the validity of often practiced spatial decomposition methods in very large-scale electric power networks, and conditions for localized response [34], [35]. The complex-valued power flow constraint (22) can be further written as two sets of real-valued nonlinear equations representing real power and reactive power balance equations⁵

$$P^N(\delta, E) = P \quad (24)$$

$$Q^N(\delta, E) = Q. \quad (25)$$

Because of line power flow dependence on nodal voltages and angles, a general model of power system dynamics comprises both the closed-loop dynamics of its components, power generators in particular, and the coupled real power-voltage power flow constraints, respectively. Consequently, the general model is given as a differential algebraic equation (DAE) model of coupled equations (16), (17), (24), and (25). This model is expressed in terms of physical variables, and is generally used by the power engineers to simulate a system response to various changes of interest. We next restate the same model for systems researchers who may not be familiar with electric power systems.

A. General DAE State Space Model

For purposes of systems control modeling of electric power systems, the same DAE model can be rewritten in terms of local state variables of the G–T–G set and excitation system

$$x = x_{\text{LC}} = [x_{\text{LC}}^P \quad x_{\text{LC}}^Q]^T \quad (26)$$

where

$$x_{\text{LC}}^P = [\delta \quad \omega_G \quad P_{\text{mech}} \quad a]^T \quad (27)$$

is its electromechanical characterization and

$$x_{\text{LC}}^Q = [e'_q \quad e_{\text{fd}} \quad V_R \quad V_F]^T \quad (28)$$

is its electromagnetic characterization.

A structure-based modeling requires representing the characterization of each component i in terms of its own local states x_{LC}^i , local output variables y_{LC}^i , local control feedback u_{LC}^i and local reference values $y_{\text{LC}}^{i,\text{ref}}$ to which the local controller responds automatically. Using systems

⁵Superscript N highlights the network side of the power flows.

control terminology, the local dynamics of component i (13)–(17) can be represented as

$$\dot{x}_{LC}^i = f_{LC}^i(x_{LC}^i, y_{LC}^i, u_{LC}^i) \quad (29)$$

Local controllers on power plants have control

$$u_{LC}^i = [a \quad e_{fd}]^T \quad (30)$$

and the local outputs

$$y_{LC}^i = [w_G \quad E_G]^T. \quad (31)$$

Local control generally responds to the local error

$$e_{LC}^i = y_{LC}^i - y_{LC}^{i,ref}. \quad (32)$$

The closed-loop dynamics of individual components (29)–(32) combined with the algebraic constraints (24) and (25) written in terms of output variables of system components y , local states x , inputs u , and system parameters p result in a set of DAEs in state-space form with well-defined states, outputs, and control as follows:

$$\dot{x} = \tilde{f}(x, u, y, p) \quad (33)$$

$$0 = g(x, u, y, p). \quad (34)$$

This model has much structure, see [29, Ch. 4]. Based on this, we summarize that a general nonlinear dynamic model of an electric power grid is represented as a coupled set of DAEs (24), (25), and (29)–(32). Because the real-world power networks are huge, the numerical tools for simulating the time-domain responses defined by this model have only been used for off-line planning studies. Given the overall challenge in the area of DAEs [70], numerical methods for simulating these for large power systems remains an enormous challenge [11]. Nevertheless, these models are essential for off-line transient stability studies of system response to very large critical equipment failures.

We close by observing that the DAE model presented could be further generalized to account for many discrete controllers present in the system, see [29, Ch. 4]. Many power lines and end users have local discrete controllers such as on-load tap changing transformers (OLTCs), shunt capacitor, and/or inductor banks. These are mechanically switched devices with typical delays longer than the time

required for the closed loop power plants to stabilize their dynamics. This discrete control is of the form

$$u_i[(k+1)T] = u_i[kT] - d_i r_i(e_i[kT]) \quad (35)$$

acting only at discrete times kT , $k = 1, 2, \dots$ and in discretized values d_i . Over the past decade or so fast power electronic local controllers have also been added to areas with unusual dynamic problems. For modeling purposes both mechanically switched and electronically powered controllers can be included in this DAE model.

B. Frequently Used Models and the Underlying Assumptions

The general DAE model presented here is related to the well-established models currently used by the industry for main-stream research and development [51], [82]. These are generally a set of models divided by the time span covering the phenomena of interest, ranging from milliseconds to years. The set of standard models consists of models representing: 1) electromagnetic transients; 2) transient stability; 3) mid-term and long-term dynamics; 4) frequency dynamics; 5) steady-state power flow; 6) operational planning; and 7) investment planning. Each one of these models is intended for specific studies. Using power engineering terminology, models 1) and 2) are used for protection, models 2)–5) are for control, models 5) and 6) for scheduling and dispatch, and models 6) and 7) for planning. For each of the category, the industry model is fairly standard. In current practices for control, models 2)–4) are used in the analysis to develop off-line, open-loop control actions. AGC, which is part of on-line feedback control, utilizes combinations of models 4) and 5). Detailed frequency dynamic models are used for under-frequency relay setting. AGC uses a simplified frequency dynamic model. The other on-line control functions are done in the control center (EMS—SCADA) that uses the model in 5). There is no single model encompassing the whole span of functions. The use of a set of models is not unique in power engineering. Modeling with different granularity is commonly done. What is lacking are interfaces between the models that are seamless.

One of more difficult challenges perceived by the broader research community has been the lack of well-established models for electric power systems. The general DAE model described here is hardly ever used. The reasons for this are likely twofold. First, it is practically impossible at present to develop any systematic monitoring and control framework for the predictable performance of the system characterized by this general DAE model. Second, such complex models are not always needed. The level of detail and assumptions made are context-dependent. This contingency has led to a variety

of models available throughout the literature. However, to a nonspecialist in power engineering, these models are hard to put in context.

It is, therefore, important to review the simplifications of a general model into more specialized models which have been utilized by researchers and utilities over the past three to four decades. The simplified models must be understood in the context of assumptions made and their intended use. Here we do not provide a complete assessment, but point out that qualitatively different models are available throughout the literature. For example, depending on how loads are modeled, one could have a representation of the same system by network system models with hundreds of nodes or with tens of thousands of nodes. In particular, if loads are modeled as constant impedances or constant current injections, star-delta network equivalencing can be applied to reduce the large network to a network with only nodes to which generators are connected. As part of this process one loses many unique nonlinear problems which may be experienced when loads absorb near constant power independently from the operating conditions [2]. Nevertheless, this is usually done when one is performing simulations of large-scale systems in order to assess whether the system is transiently stable in response to large equipment outages, or estimating the so-called critical clearing time within which the failure must be repaired in order for the system to return to stable operation following a fault.

Major simplifications are frequently introduced by assuming that the real power and the corresponding electromechanical variables (frequency, generator rotor angle) are decoupled from the reactive power and electromagnetic variables (voltage behind the transient reactance of a generator). Most of the models for simulating the out-of-synchronism problem following large power plant outages are derived by making this real power-voltage decoupling assumption. Up until the early 1980s, the dynamics of the electromechanical variables primarily were modeled in order to assess the worst case stability problems. This simply means that the electromagnetic variables (28) were assumed constant and only the dynamics of electromechanical variables (27) were modeled as (16) subject to real power network constraints (24). A combination of (16) and (24) degenerates into a set of ordinary differential equations (ODEs)

$$\dot{\delta}_G = \omega_G - \omega_G^{\text{ref}} \quad (36)$$

$$M\dot{\omega}_G = P_{\text{mech}} - A^T p - D(\omega_G - \omega_G^{\text{ref}}). \quad (37)$$

This is known as the “classical” nonlinear dynamic model of an interconnected power system [58]. This model has been used extensively for simulating very fast responses to real power outages, for the duration of time prior to which the P_{mech} can be adjusted and before

electromagnetic variables begin to vary. This is an example of time-scale separation based on model simplification for specific analysis. This model, although nonlinear, has a tremendous structure [12] that shares much in common with the general nonlinear resistive–inductive (RL) networks [87]. Moreover, if the resistances are neglected, the model lends itself to the rich class of Lagrangian systems [12] and their many qualitative properties. Unfortunately, neglecting resistances effectively means neglecting not only the resistances of the transmission lines in an equivalenced network, but also loads, and this greatly detaches the model from real-world systems. Later, a so-called structure preserving model was proposed to overcome this problem. A state dependent load dynamics of a form similar to the local dynamics of generators was introduced. This resulted in a high-order ODE model, in which many predictable properties of large-scale sparse network systems, despite the high-order, are maintained. Researchers have studied in considerable depth the properties of the classical nonlinear real power model using a variety of technical tools [76].

However, the validity of the classical real power dynamic model came into question after real-world electric power systems began to exhibit electromagnetic instabilities and a voltage collapse problem was experienced in several real-world systems [92]. It turns out that the richness of these newly emerged dynamic phenomena has continued to challenge the research community to this day, twenty years after. The causes of these reactive power-voltage instabilities are multifold. Most generally, the inherent assumption in the classical model that the electromagnetic variables do not change right after the disturbance underlying their decoupling from electromechanical variables no longer holds, since the rate of change of the voltages approaches infinity [77]. This also pushes the validity of phasors to its limits, requiring partial differential equations (PDEs) representation. It has been difficult to verify different forms of voltage collapse in real-world scenarios, and there has not been definitive agreement on this. Conceptually, the instability in a coupled DAE general model can be reflected through: 1) nonlinear phenomena in which a disturbance takes the state outside stable regions to the regions of unstable equilibria; 2) small signal instability around an operating point [52]; and/or 3) nonexistence of an equilibrium for the set of parameters and available controls with current logic and strictly local control logic of both generator controllers and mechanically switched controllers [54]. It is in the context of these issues that current state-of-the-art modeling does not lend itself well to interpreting in a verifiable way real-world emerging behavior problems. We review methods used by human operators to avoid such difficult problems for which the validity of the model is questionable and the analyses are very complex. It is important to explore potential of novel monitoring and control approaches for possible enhanced automation during such conditions

when the problem complexity is beyond a human's ability to manage it.

V. STRUCTURE-BASED MODEL AS A BASIS FOR HIERARCHICAL MONITORING AND CONTROL

In this section we state the key assumptions underlying hierarchical monitoring and control of today's electric power systems. The objective is to introduce simpler classes of models than the general ones described above which could be used for monitoring and controlling electric power systems during normal conditions. One systematic way is to start with the general model and identify mathematical conditions which must be critically met in order to derive the basic models relevant for defining the hierarchical control of today. This approach is relevant because today's hierarchical control was not designed for guaranteed performance; it is a best-performance design, instead. In [28] it was shown how structure-based modeling can be used to enhance hierarchical control and incrementally improve its performance. It is with this second objective in mind that we pursue a systematic assessment of modeling assumptions in this paper.

To start with, one of the basic assumptions is that a generalized model linearization is valid for the range of operating conditions during normal conditions as disturbances around the forecast are assumed to be small. Consider a linearized local dynamics of a G-T-G set (16)

$$M\dot{\omega}_G + D\omega_G = P_{\text{mech}} + e_T a - P_G \quad (38)$$

$$T_u \dot{P}_{\text{mech}} = -P_{\text{mech}} + K_t a \quad (39)$$

$$T_g \dot{a} = -ra - \omega_G + \omega_G^{\text{ref}} \quad (40)$$

where all quantities represent deviations of the variable from its equilibrium.⁶ Based on this and the definition of local states, the linearized primary dynamics of electro-mechanical variables for each G-T-G set can be rewritten in a matrix form

$$\dot{x}_{\text{LC}}^P = A_{\text{LC}}^P x_{\text{LC}}^P + c_M P_G. \quad (41)$$

Similarly, the linearized dynamics of local electromagnetic dynamics (17) takes on the form

$$\dot{x}_{\text{LC}}^Q = A_{\text{LC}}^Q x_{\text{LC}}^Q + C i_d. \quad (42)$$

⁶ ω_G^{ref} is a frequency reference of interest, and it is constant unless it is changed by the AGC. In this section we assume no AGC action and omit this term until later in the paper.

The entire local state of the coupled process is

$$x_{\text{LC}} = [x_{\text{LC}}^P \quad x_{\text{LC}}^Q]^T \quad (43)$$

and its local dynamics are

$$\begin{bmatrix} \dot{x}_{\text{LC}}^P \\ \dot{x}_{\text{LC}}^Q \end{bmatrix} = \begin{bmatrix} A_{\text{LC}}^P & 0 \\ 0 & A_{\text{LC}}^Q \end{bmatrix} + \begin{bmatrix} C_M & 0 \\ 0 & C \end{bmatrix} + \begin{bmatrix} P_G \\ i_d \end{bmatrix}. \quad (44)$$

In order to express network constraints, we partition both real and reactive power flow (24) and (25) into the corresponding power flow equations at the generators and loads, respectively. Moreover, real power injections into both generator nodes and load nodes are decomposed into those being injected by the power plant itself P_G and the injections from outside the control area F_G^P , $-P_L^P$ and F_L^P . This is done for purposes of modeling the intercontrol area dynamics and the secondary (control area) level hierarchical control explicitly. Shown in Fig. 1 are the boundaries of typical control areas within a large electric power interconnection comprising several such areas.

The decomposition into generation Q_G and load Q_L nodes is also done for the reactive power flow constraints (25); both of these injections are further decomposed into the injections coming directly from the generators i_d and loads $-i_L$ and the injections from outside the control areas F_G^Q and F_L^Q , respectively. By further explicitly stating that the power flows in the transmission lines are nonlinear functions of nodal voltages and angles at both generators V_G , δ_G , and loads V_L , δ_L , the coupled real and reactive power flow constraints (24) and (25) take on the form

$$P_G^N(\delta_G, \delta_L, V_G, V_L) = P_G + F_G^P \quad (45)$$

$$P_L^N(\delta_G, \delta_L, V_G, V_L) = -P_L + F_L^P \quad (46)$$

$$Q_G^N(\delta_G, \delta_L, V_G, V_L) = Q_G^{\text{norm}} = i_d + F_G^Q \quad (47)$$

$$Q_L^N(\delta_G, \delta_L, V_G, V_L) = Q_L^{\text{norm}} = -i_L + F_L^Q. \quad (48)$$

Furthermore, assuming that these algebraic constraints are differentiable, after differentiating all four power flow constraints (45)–(48) with respect to time, solving (46) and (48) for $[\delta_L \dot{V}_L]$ and substituting into (45) and (47) these equations take on the form

$$\begin{bmatrix} \dot{P}_G \\ \dot{i}_d \end{bmatrix} = [\mathcal{E}_1 \quad 0] \begin{bmatrix} x_{\text{LC}}^P \\ x_{\text{LC}}^Q \end{bmatrix} + [0 \quad \mathcal{E}_2] \begin{bmatrix} \dot{x}_{\text{LC}}^P \\ \dot{x}_{\text{LC}}^Q \end{bmatrix} + \mathcal{G} \quad (49)$$

with E_1 and E_2 relating $\omega_G = E_1 x_{LC}^P$ and $e'_q = E_2 x_{LC}^Q$, and

$$\mathcal{E}_1 = (J_3 - J_4 J_2^{-1} J_1) E_1 \quad (50)$$

and

$$\mathcal{E}_2 = (J_3 - J_4 J_2^{-1} J_1) E_2. \quad (51)$$

Matrices J_1 , J_2 , J_3 and J_4 are defined as

$$J_1 = J_1(\delta, V) = \begin{bmatrix} \frac{\partial P_L}{\partial \delta_G} & \frac{\partial P_L}{\partial V_G} \\ \frac{\partial Q_L^{norm}}{\partial \delta_G} & \frac{\partial Q_L^{norm}}{\partial V_G} \end{bmatrix} \quad (52)$$

$$J_2 = J_2(\delta, V) = \begin{bmatrix} \frac{\partial P_L}{\partial \delta_L} & \frac{\partial P_L}{\partial V_L} \\ \frac{\partial Q_L^{norm}}{\partial \delta_L} & \frac{\partial Q_L^{norm}}{\partial V_L} \end{bmatrix} \quad (53)$$

$$J_3 = J_3(\delta, V) = \begin{bmatrix} \frac{\partial P_G}{\partial \delta_G} & \frac{\partial P_G}{\partial V_G} \\ \frac{\partial Q_G^{norm}}{\partial \delta_G} & \frac{\partial Q_G^{norm}}{\partial V_G} \end{bmatrix} \quad (54)$$

$$J_4 = J_4(\delta, V) = \begin{bmatrix} \frac{\partial P_G}{\partial \delta_L} & \frac{\partial P_G}{\partial V_L} \\ \frac{\partial Q_G^{norm}}{\partial \delta_L} & \frac{\partial Q_G^{norm}}{\partial V_L} \end{bmatrix} \quad (55)$$

and

$$\mathcal{G} = J_4 - J_2^{-1} \dot{c}_1 - \dot{c}_2 \quad (56)$$

where c_1 accounts for the effects of real and reactive power load deviations, and is defined as

$$c_1 = [(F_L - P_L \quad (Q_L^{norm} + F_L^Q)]^T \quad (57)$$

and c_2 is defined as

$$c_2 = [P_G \quad F_G^Q]^T. \quad (58)$$

The standard state-space formulation of the coupled real power/voltage dynamics is obtained by combining (44) and (49) into

$$\mathcal{I} \begin{bmatrix} \dot{x}_{LC}^P \\ \dot{x}_{LC}^Q \\ \dot{P}_G \\ \dot{i}_d \end{bmatrix} = \begin{bmatrix} A_{LC}^P & 0 & C_M & 0 \\ 0 & A_{LC}^Q & 0 & C \\ \mathcal{E}_1 & 0 & 0 & 0 \end{bmatrix} \begin{bmatrix} x_{LC}^P \\ x_{LC}^Q \\ P_G \\ i_d \end{bmatrix} + \begin{bmatrix} 0 \\ \mathcal{G} \end{bmatrix} \quad (59)$$

where $\mathcal{I} = I - [0 \ \mathcal{E}_2 \ 0 \ 0]$. Model (59) is in the standard state-space form in the extended state space $x = [x_{LC}^P \ x_{LC}^Q \ P_G \ i_d]$, if \mathcal{I} is generally invertible.

Matrices J_1 , J_2 , J_3 , and J_4 are operating conditions dependent in the generalized linearized version of the model. If they are evaluated around an operating point once, the same model represents a coupled real power/voltage small signal linearized dynamic model. The relevance of transforming the DAE model into an ODE model is far reaching with respect to the tools available for analysis and control design conditions. We have shown here that as long as several key conditions (such as the validity of differentiating algebraic constraints with respect to time, the invertibility of matrix J_2 , and the invertibility of matrix \mathcal{I}) are satisfied, it is possible to derive a much more user-friendly model for monitoring and control considerations. In the section on abnormal conditions we further discuss the potential relevance of these conditions and their relations to the role of human operators and currently used numerical tools in the SCADA centers. For purposes of formalizing the hierarchical control problem, it suffices to start by using model (59) and introducing the assumptions required for the temporal and spatial decomposition inherent in today's hierarchical control of large-scale electric power systems.

A. Continuous Interaction Variables and Inter-Area Dynamics

There is much hidden structure in model (59). For example, when a control area is isolated (a power grid of an island), F_G^P , F_G^Q , F_L^P and F_L^Q are identically zero. As long as the local dynamics are stable at each component level for the range of real power, the stability of the system is determined by the properties of matrices J_1 through J_4 . For example, when matrix J_2 is nonsingular, the dynamics of the coupling variables is directly caused by the deviations in loads around their forecast and by the deviations in real and reactive power injections from outside the control area. Fundamental to establishing structure-based thinking for this class of electric power systems is the observation that there are no interarea swings unless there are deviations in the imports/exports of power from their preagreed values.⁷ This leads us to introducing a notion of interaction variables as a means of modeling structural dynamics at the secondary, interarea level within an interconnected electric power grid [28], [36], [37]. To summarize this notion, observe that for an interconnection with M control areas, the dynamics of each area J is represented as

$$\dot{x}^J = A^J x^J + \dot{F}_e^J - D_p^J \dot{P}_L^J. \quad (60)$$

⁷This statement is true as long as J_2 is also invertible. See further discussion of this in the section on abnormal conditions.

This is simply model (59) rewritten in a more concise form. This model implies that the dynamics of state variables in each area directly depend on the state variables in the same area x^J , and the dynamics of the tie-line flows into the area F_e^J . Notice that this model accounts for the electrical distances of the network represented in the properties of the area system matrices A^J and D_p^J . This model is used in [36], [37] to introduce a notion of interaction variables z^J between a control area and the rest of the interconnection as a particular linear combination of state variables inside each control area whose dynamics can only be affected by changes outside a control area. For completeness, define a linear combination of state variables x^J inside a control area as

$$z^J = P^J x^J \quad (61)$$

with the participation factor satisfying

$$P^J x^J = 0. \quad (62)$$

The interarea dynamics are simply defined by premultiplying the dynamics of each control area (60) by the corresponding participation matrix P^J to obtain

$$\dot{z}^J = P^J [0 \dot{F}_e^J]^T + P^J [0 - D_p^J]^T \dot{P}_L^J = P^J (\dot{F}_e^J - D_p^J \dot{P}_L^J). \quad (63)$$

Clearly, we see that the interarea variables z^J vary due to the tie-line power flow injections for a constant power load in the area. From here we see that the fundamental cause of the interarea dynamics lies in the interarea power exchanges. This can not be seen using more conventional unstructured models of an electric power interconnection.

B. Decoupled Real and Reactive Power Inter-Area Dynamics

A second major assumption routinely made in today's hierarchical feedback control is that real power and voltage dynamics are largely decoupled. Under this assumption, one can decouple the continuous interarea dynamics (59) into its real power component [36], [37] and its reactive power component [29]. We briefly summarize these findings here, as they are important for understanding the hierarchical modeling and control basis for large-scale electric power systems.

C. Structural Existence of the Decoupled Continuous Real Power Inter-Area Dynamics

Consider a single control area with the interaction variables defined as in (61) above, and the condition for the existence of such variables given in (62). Under

the decoupling assumption this condition (49) takes on the form

$$\dot{P}_G^J = K_p^J (\delta^J) \omega_G^J + \dot{F}_e^J - D_p^J (\delta^J) \dot{P}_L^J. \quad (64)$$

The basic structure of the nonlocalized interactions between a single control area and the neighboring areas is defined by the properties of matrices⁸

$$K_p = \left[\frac{\partial P_G}{\partial \delta_G} \right] - \left[\frac{\partial P_G}{\partial \delta_L} \right] \left[\frac{\partial P_L}{\partial \delta_L} \right]^{-1} \left[\frac{\partial P_L}{\partial \delta_G} \right] \quad (65)$$

and

$$D_p = \left[\frac{\partial P_G}{\partial \delta_L} \right] \left[\frac{\partial P_L}{\partial \delta_L} \right]^{-1}. \quad (66)$$

This formulation is a particular case of the formulation in (49) obtained when neglecting the sensitivities of real power with respect to voltage terms in the sensitivity matrices J_1 through J_4 .

It was shown in [28], [36], and [37] that for the case of real power dynamics such an interaction variable exists and it is structurally defined and interpreted as the total supply/demand real power imbalance inside a control area. The condition (62) is equivalent to the condition that $K_p \mathbf{1} = 0$, which is further equivalent to the row sum of K_p being 0, or $\mathbf{1}$ being the right eigenvector corresponding to its zero eigenvalue. This property follows as a direct consequence of the fact that the row sum of the incidence matrix is always 0 [13], [29]. Therefore, one can claim that there exists a unique P^J (up to a scalar) whose dimension is $1 \times (n_G^J + n^J)$, where n_G^J is the number of the generators in the control area J and n^J is the number of the local state variables of all generators in area J . This participation factor can be further written as

$$P^J = [0 \quad p^J] \quad (67)$$

where p^J is a matrix to be determined from condition (62). For lossless power systems it is straightforward to show that $p^J = \mathbf{1}$. Therefore, for the case of decoupled real power dynamics the interaction variable assuming negligible resistive losses simply becomes

$$z^J(t) = \sum_{l=1}^{l=n_G^J} P_{G,l}^J(t). \quad (68)$$

⁸In what follows superscript J denoting area J is omitted for notational simplicity.

This implies that $z^J(t)$ is constant, assuming a constant real power load model and constant losses in an isolated power network. This notion of interaction variables is useful for relating engineering concepts such as automatic generation control (AGC) with the more formal systems control for large-scale horizontally organized electric power interconnections. For further relations between the G–T–G droop characteristics and the model presented here, see [29]. Of particular interest is the hard-to-capture dependence on network topology and its parameters. The structure-based model presented here explicitly defines these in terms of the K_P and D_P matrices.

There is much physical intuition to be gained from simulating the real power interarea dynamics of electric power systems. For the simple case of the two control area system shown in Fig. 1 and typical network parameters a time-domain response of both coupling variables $P_{G,i}^J$ in each control area J and the dynamics, see [28], [29, Ch. 6], [36], [37]. It is important to observe the relative rate of change of the coupling variables of individual generators inside each control area and the rate of change of the interarea variables, representing the aggregate power imbalances between the control areas.

D. Structural Nonexistence of the Decoupled Continuous Voltage Interarea Dynamics

The existence of continuous time interarea real power dynamics based on the structural properties of the network should be contrasted with the qualitatively different nature of continuous time voltage dynamics assuming decoupling between real power and voltage dynamics. Following an analogous derivation as for deriving the decoupled real power dynamics, the following form of the decoupled voltage dynamics is obtained as [28]

$$\begin{bmatrix} \dot{x}_{LC}^Q \\ \dot{i}_d \end{bmatrix} = \begin{bmatrix} A_{LC}^Q & C \\ K_Q(V)E & 0 \end{bmatrix} \begin{bmatrix} x_{LC}^Q \\ i_d \end{bmatrix} + \begin{bmatrix} 0 \\ \dot{F}_Q - D_Q(V)\dot{Q}_L \end{bmatrix} \quad (69)$$

where A_{LC}^Q is the system matrix corresponding to the dynamics of electromagnetic variables in (17), $K_Q(V) = [\partial Q_G / \partial V] - [\partial Q_G / \partial V_L] [\partial Q_L / \partial V_L]^{-1} [\partial Q_L / \partial V_G]$ and $V = [V_G V_L]$ is a vector of all generator and load voltages in the area J , respectively.

For understanding the qualitative differences between the nature of real power and voltage dynamics within a multiarea electric power system, it is of crucial importance to recognize that the structural properties of $K_P(\delta)$ do not hold for the analogous matrix $K_Q(V)$. Matrix $K_Q(V)$ has a structurally full rank, and therefore does not have the zero eigenvalue inherently present in $K_P(\delta)$. This implies further that a general existence of interarea variables can not be guaranteed for the decoupled voltage dynamics and, therefore, the voltage response to small disturbances in reactive power injections during normal conditions is

generally localized within each control area. While the practitioners often state that voltage response is localized and that it can be only controlled by dispersed local capacitive/reactive power compensation, the mathematical foundations in support of this claim and conditions under which this holds have not been formalized. The structure-based model introduced here in (59) begins to help with understanding at least what the sufficient conditions are for this property. One should not overlook, however, the many implied assumptions on the path to obtaining these models. Later in this paper we revisit these assumptions when considering abnormal conditions.

VI. STRUCTURE-BASED APPROACH TO HIERARCHICAL CONTROL DESIGN: TEMPORAL AND SPATIAL DECOMPOSITIONS FOR DISTRIBUTED PERFORMANCE OBJECTIVES

Hierarchical control of today's large-scale electric power system is a result of carefully engineered simplifications intended to meet the distributed objectives of its horizontal organization. Today's hierarchical control is heavily dependent on temporal and spatial decompositions.

A. Basis for Temporal Decomposition

One possible way of conceptualizing the hierarchical control design of large-scale electric power systems is to think of load deviations as the main reason for automated control during normal conditions. For good quality of service (QoS) it is necessary for supply and demand to balance, and generation control automation is dedicated to responding to changes in load to maintain this balance. For purposes of formalizing the hierarchical control principles in today's industry, it suffices to model deviations of real and reactive power demand at node j around the forecast⁹

$$P_{Lj} = P_{Lj}[W] + P_{Lj}[D] + P_{Lj}[H] + P_{Lj}[M] + d_{Lj}^p[t] \quad (70)$$

and

$$Q_{Lj} = Q_{Lj}[W] + Q_{Lj}[D] + Q_{Lj}[H] + Q_{Lj}[M] + d_{Lj}^q[t]. \quad (71)$$

Here (70) and (71) define a discretized representation of a typical load into its weekly $[W]$, daily $[D]$, hourly $[H]$, and minute $[M]$ components; the near real-time load

⁹Recall that feed-forward scheduling is done to meet forecast demand. Hierarchical feedback control is only intended to respond to hard-to-predict demand deviations. It should be clear that the more accurate the demand forecast, the less that will be expected from the automated control.

component is represented as an unpredictable disturbance $d(t)_{L_j}^P$ and $d(t)_{L_j}^Q$ superposed to the other load components assumed to be possible to forecast. Both the real and reactive power loads are modeled, respectively.

B. Basis for Spatial Decomposition and Decentralized Control

The property of (block) diagonal dominance in electric power networks [32] can be used to support the spatial decomposition of a complex interconnection into its horizontally organized control areas. This principle is a theoretical basis for effective spatial decomposition and for the hierarchical management of large electric power interconnections during steady state normal operation. There have been several important concepts, notably the concept of diakoptics, used as theoretical methods for decomposing the complex system [23], [50], [84]. However, the diakoptics approach requires a single step coordination of decomposed subsystems in order to optimize the large-scale system; the basis for this comes from the seminal work on tensor analysis of electric circuits [50].

At present the on-line information structure is at the control area level. No on-line coordination of control areas is in place. Instead, the coordination has taken place in the past through cooperative agreements about net real power flow exchanges between the control areas. These agreements generally results in suboptimal use of the interconnection resources, and it does not create any other major problems during normal operating conditions. However, during unexpected equipment failures sometimes domino effects of changes in one control area have been known to take place, affecting the integrity of the entire system. Such events raise a major question concerning on-line information exchange between hierarchically structured control areas for improving both the efficiency of utilizing existing resources and/or for preventing cascading failures during equipment failures [88].

C. Mapping of Temporal Decomposition, Spatial Decomposition, and Distributed Performance Objectives

The structure-based models of the hierarchical electric power systems formalized in Section V lend themselves naturally to a model-based implementation of current operating practices. A detailed treatment of this can be found in [28], [29], and [31], and only its summary is presented here. Important for assessing the evolving open access paradigms for future grids is the observation that current operating practices are based on the straightforward mapping of temporal and spatial decompositions of system dynamics by means of single performance sub-objectives at the various layers of the system hierarchy. Simply said, continuous fast dynamics are controlled locally at a component level, while slower variations in demand and deviations from preagreed on tie-line flow

exchanges with the neighboring systems are regulated by means of automatic generation control (AGC) at each subsystem level, defined as a control area within a horizontally organized system. These two control functions are automated feedback functions. In addition, the human operators schedule generation in a feed-forward way to balance the forecast demand.

In today's hierarchical control of large electric power systems there exists an implied one-to-one equivalence among:

- **Primary/Fast/Local Representation** of a near real-time load deviation $d_L^P(t)$ and $d_L^Q(t)$ in (70), (71) and the spatial deviation of real power $P_{G,i}^J(t)$ as the coupling variables between the generator i within a control area J ;
- **Secondary/Slower/Area Representation** of a slower load deviation $d_L^P[M]$ in (70), (71) and the area-level interaction variables $z^J[T_s]$ assuming that continuous time interarea interactions $z^J(t)$ stabilize the response to minute-to-minute load deviations;
- **Tertiary/Slow/Regional Representation** of the slow load forecast $d_L^P[H]$ in (70) and (71) and the preagreed on interaction interarea exchange $z^J[T_i]$ between the control area and the others.

D. Secondary Level Automated Generation Control (AGC)

Given this implied temporal-spatial mapping, a notation reflecting spatial decomposition into a secondary level and the corresponding temporal sampling at this level T_s and the tertiary level and its corresponding temporal sampling T_t is used next for summarizing the structure-based hierarchical models and to conceptualize the corresponding control objectives and design. Each sampling time interval corresponding to the secondary control T_s the set points of power plants participating in area-level AGC $v^{\text{ref}}[k] = v^{\text{ref}}(kT_s)$ are updated, and are unchanged for $kT_s \leq t \leq (k+1)T_s$. With this notation, one obtains the area-level structure-based model directly from (63) by superposing the effects of changes in set points of primary controllers as follows¹⁰:

$$\dot{x}(t) = A(t) + B(t)v^{\text{ref}}[k] + UF(t) + V\dot{F}(t). \quad (72)$$

Keeping in mind that the main objective of the secondary-level control is to eliminate slower drifts in some state variables (frequency, in particular) $x_s = Dx$, with the dimension of x_s much lower than the dimension of full state inside the area, and assuming that both state variables

¹⁰Superscripts J denoting area J are assumed, and eliminated for simplicity.

and very fast interactions between the control area and the rest of the system settle in between the secondary level sampling intervals, namely that $\dot{x}(t) \approx 0$ and $\dot{F} \approx 0$, one obtains [28], [29] a structure-based model for secondary level control design

$$x_s[k+1] = x_s[k] + B_s u_s[k] + M_s F_s[k] \quad (73)$$

where $B_s = -DB$, $M_s = -DU$, $u_s[k] = v^{\text{ref}}[k+1] - v^{\text{ref}}[k]$ and $F_s[k] = F[k+1] - F[k]$. Model (73) was proposed as the simplest model for designing systematically output feedback-based secondary level control for meeting the desired performance at the control area level. The corrective control signal is an integral controller as the model does not include any continuous fast dynamics.

In order to illustrate this design, let us assume m output variables related to critical states as

$$y_s[k] = C_s x_s[k]. \quad (74)$$

The conventional secondary control of normal operation takes on a simple proportional form

$$u_s[k] = G(y_s[k] - y_s[T_t]) \quad (75)$$

where $y_s[T_t]$ is the value of the output feedback set at the tertiary level. As an illustration of this control design, if one considers meeting the following secondary level performance criterion

$$J_s = \sum_{k=0}^{\infty} (y_s[k]^T Q y_s[k] + u_s[k]^T R u_s[k]) \quad (76)$$

the secondary control becomes a linear quadratic regulator design problem [28], [29], [31].

An interesting degenerate case of this control design would be the load-frequency control which preceded today's AGC. This case occurs when only one frequency measurement is carried out by the entire control area, and it is used as the output variable; in addition, matrix R takes into consideration the fuel cost of the power plants participating in this control, while matrix Q is not standardized.

It is clear from the secondary-level model that the slow variations in tie-line flows affect the output variables of interest as well. To compensate fully for the effect of interconnections, a modified control law of the form

$$u_s[k] = G(y_s[k] - y_s[KT_t] + HF_s[k]) \quad (77)$$

was proposed in [28] and [29], where it was shown that with the choice of $H = -U_s^{-1}C_s M_s$ flows do not enter the closed-loop model.

There exist interesting theoretical links between this improved secondary level control and today's AGC. The so-called area control error (ACE) signal is a linear combination of frequency deviation at a single location inside the control area and the net tie-line flow deviation. Long-term industry performance criteria for AGC has been for ACE to cross zero at least once every 10 min [9].

Due to space limitations we omit the derivation of the secondary level model in support of the automated secondary voltage control which has been successfully implemented in France, Italy, and Spain over the past 20 years. Instead of using control area frequency the automated secondary voltage control is based on measuring load voltages as the key output measurements at several key load centers ("pilot points") within the control area [59], [72]. The secondary voltage control has been proposed for consideration in the United States, but is not currently in place.

E. Tertiary Level Coordination: The Missing Piece

The tertiary level concerns system performance at a regional, multicontrol area level and over a slower time scale T_t . Since interregional interactions take place through deviations in tie-line flows away from those pre-agreed on at the scheduling stage, regulating these is of direct concern for meeting system-wide performance. A sufficient information structure for this coordination would utilize the measurement of tie-line flows $F[K]$ and the dedicated controllers $v^{\text{ref}}[K]$ for meeting the preset criteria. At present such criteria and its objectives have not been formalized by the industry. Instead, tie-line flows vary around the targeted day ahead $[D]$ or even week ahead $[W]$ preagreed on net tie-line flow exchanges in a free-flowing fashion. During normal conditions the interconnection is generally operated suboptimally, both over time and space. Most generally, the decomposition into uncoordinated decentralized scheduling by the control areas leads to the suboptimal use of resources in the interconnection as a whole. Similarly, decomposing a stochastically varying load and carrying out static deterministic optimization over each time horizon leads to much volatility and many inefficiencies. These problems could be minimized with an on-line tertiary coordination in place.

VII. FUTURE CHALLENGE OF AUTOMATED OPERATION DURING ABNORMAL CONDITIONS

As outlined above, today's hierarchical control is based on many implied assumptions. There have been numerous events when the primary controllers have failed to stabilize system dynamics, resulting in major system disintegration,

in particular during major system blackouts [75]. Even when the system is not in such an extreme condition, it is hard to have predictable performance for disturbances of interest.

Even steady-state performance is not fully predictable given that there is no on-line coordination of system control areas. While this problem was recognized early on following the first blackouts, there has been very little theoretical work concerning the potential of a more coordinated system-wide scheduling of resources for enhancing reliable operations during large equipment outages resembling typical blackout scenarios [44]. Hidden, typically low frequency swings, have been known to take place between the generators, even between those placed in different control areas. For a real-world example of this problem, in particular power plants in New England and New York experiencing around 0.7 Hz swings, see [49]. If the electric power grid is viewed as a structure of interconnected components responding in a highly localized way to local disturbances, this behavior must be seen as abnormal. Small variations at one location create oscillations across vast geographical and electrical distances. This issue raises fundamental questions concerning the existence of such interaction variables across control areas and the need for their modeling and control. Here, again, there has been more than one explanation of such phenomena, and the opinions are divided as to whether this phenomena can be captured using only nonlinear models, or if these events are more structural in nature and could be detected using even linearized models when network parameters are such that electrical connections between the areas are relatively strong.

The limiting challenge in operating today's electric power systems is generally seen when the system enters conditions for which no preventive actions are in place [43]. This occurrence can happen in a variety of scenarios, most of which are a combination of extreme demand variations around the forecast and large equipment failures. As a rule, it is impossible for real-world electric power grids to explore all possible combinations off-line in order to define the worst case system conditions and prepare procedures for when these take place. Nevertheless, the engineers have taken a pragmatic approach to defining the worst case scenarios for their control areas, and, to some extent, for the region as a whole. The worst situations are a combination of probabilities of such events taking place and their severity. During extreme conditions human operators are the only decision makers, and the secondary level AGC is often disabled.

As the electric power systems begin to be more tightly coupled for economic reasons during normal conditions, the effects of larger demand deviations and equipment outages have begun to have system-wide effects. Depending on the severity of the situation, operators most of the time manage to keep the system from experiencing widespread effects.

A. The Newly Emerged Problem of Voltage Instability

In the early 1980s a major complication surfaced. There was no sufficient reactive power compensation on a primarily inductive network (wires and loads) to ensure that voltages remain at physically acceptable levels. The industry witnessed a sequence of voltage-related blackouts, starting in France, and followed by the blackouts in Belgium, South Africa, and California. Many of the more recent blackouts have been caused by the lack of reactive power voltage support and inadequate protection [90]. In order to avoid future reactive power compensation related operating problems, much R&D is taking place considering the problem and possible means of avoiding it by deploying at many locations controllable reactive power devices, such as on-load-tap-changing transformers, capacitor-inductive shunt banks, series capacitive banks, and the like. As a result of this, the existing electric power network interconnecting the generators to consumers is primarily resistive-inductive with some shunt and series fixed and controllable capacitive compensation. The opportunities and challenges offered by reactive power compensation are far reaching [90]. Generally speaking, while this compensation enables more controllability, the dynamics of a large-scale resistive-inductive-capacitive (RLC) network becomes much more complex than that of a large-scale resistive-inductive (RL) network. This makes the probability of previously unknown emerging behavior much higher than in the past.

For an extensive analysis and possible extensions of structure-based modeling, monitoring, and control of abnormal conditions summarized in this paper, see [44]. We only highlight here the opportunity of direct control of interarea dynamics by means of FACTS devices.

B. Control Design for Inter-Area Dynamics

Simulations of multiarea systems show that, as small oscillations in each area occur in response to area load deviations, the interarea variables could also become significant. Since these are a linear combination of the faster power generation dynamics of each plant inside the area, the interarea dynamics are typically slower, see [36] and [37] for a small two-area power system interarea dynamics.

While it has been documented that such slow interarea oscillations exist in real world electric power systems [49], [73], their analysis has not been straightforward. One possible way would be to attempt and simulate the variables $z^J(t)$ and observe these slower swings of power mismatches between the control areas. As long as these oscillations settle in between the quasi-stationary changes in demand, their presence is not threatening to the interconnection system as a whole. It would be important to understand if such interactions of net power mismatches in different control areas lead to unacceptable conditions. Moreover, if needed, one should control such oscillations.

Recall from the model of the interarea dynamics (63) that the interarea dynamics are mainly affected by the fluctuations in tie-line flows into the area F_e^j . If components of F_e^j are assumed to be directly controllable, using flexible ac transmission systems (FACTS) technologies, this model can be viewed from a control design point as being of the form

$$\dot{z}(t) = pu(z) + d(t) \tag{78}$$

where $d(t)$ stands for a disturbance. In [38] one such possible control design was introduced. It is based only on measuring the interaction variable $z^j(t)$ and comparing it to the set value of the interaction variable. There is at present a major trend toward isolating portions of the grid (control areas, microgrids) and one possible technology would be FACTS devices which directly control line power flows. The structure-based models reviewed here are of great potential use for such control designs.

VIII. TOWARD OPEN ACCESS OPERATIONS OF FUTURE ELECTRIC POWER SYSTEMS

An already long to-do list in electric power systems has been made much more challenging by the ongoing technological and organizational changes. One possible way of assessing the impact of these changes is, again, by looking at the evolving industry structures.

There are basically two types of on-going industry changes. The first are technological and are the result of: 1) small-scale distributed generation (DG) becoming cost-effective [4]; 2) developing sensing and actuation technologies for customers to respond to system conditions and prices of electricity; 3) distributed switching technologies for both transmission and distribution systems; and 4) a wide spread of communications [27], [63]. With this technology in place the number of distributed decision makers and controllers is likely to increase significantly. The second driver of change has been organizational. By law, the electric power supply has become competitive, enabling customers to choose providers and go outside of their own control area to purchase cheaper power.¹¹ Similarly, generators could sell to customers outside the control areas in which they are physically located. Because of this, in [28] a typical evolving structure was referred to as being “nested,” instead of hierarchical. At the same time, in parts of the electric interconnection in which power is supplied

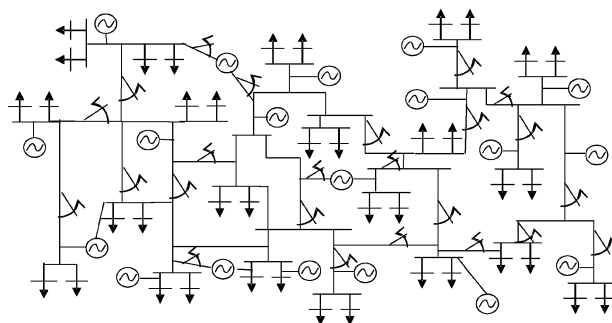

Fig. 4. Fully distributed architectures.

competitively there has been functional and corporate unbundling within once tightly coordinated control area. The main new function of wire companies is to provide “open access” delivery of power, irrespective of ownership, across the entire interconnection [74]. This is contributing to a diminishing role for control areas [29], [30].

New technologies are changing the basic electric power structure shown in Fig. 1 into network architectures shown in Figs. 4 and 5. Fig. 4 is a sketch of fully distributed industry architecture characterized by active sensing and actuation by a very large number of small actors, such as small distributed energy resources, customer response, and even automated switching of wires interconnecting these actors. This architecture was envisioned some time ago in [67]. The dynamics of interactions between various actors is determined by the distributed sensing and decision making of each actor. Each actor optimizes its own performance subobjective for the assumed environment conditions. In this sense, a single decentralized performance objective given in (3) solved centrally in the hierarchical system is solved by each actor optimizing its own subobjective with respect to his own local variables;

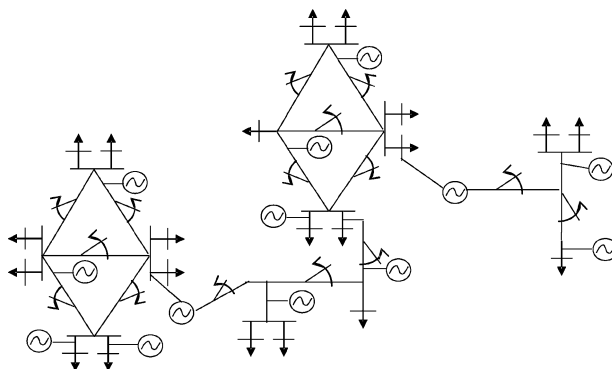

Fig. 5. Reconfiguration options for electric power grids (circles represent already controlled power plants, arrows end users, and the interconnections are controllable wires).

¹¹This is true of both large and retail customers, at least in concept. Small customers usually rely on so-called load serving entities (LSEs) which are schedulers and aggregators on behalf of groups of end users.

the constraints and interactions with the neighbors are computed for the assumed Lagrangian coefficients. Various iterative methods proposed in the recent literature naturally lend themselves to designing iterative protocols for exchanging information among the actors. One of the major open questions is if and how the system as a whole balances according to the the basic network laws (24), (25) without system-wide coordination, and, moreover, how are various constraints, in particular flow congestion constraints (8) met. Recent work in [3] indicates that this is actually possible to achieve in distributed interactive ways. Lack of storage and, therefore, the need for supply and demand to meet instantaneously according to the system-wide DAE model (33), (34) point into the fundamental research needs concerning distributed decision making and learning which takes into consideration time [90]. There is very little work so far done on this subject, and this makes the broad area of multiagent decision making not readily applicable to design of novel electric power system architectures. Fig. 5 is a more likely future architecture. Instead of equipping each piece of equipment with sensors and actuators, economic and regulatory considerations will define what is economically viable. So, instead of having fully distributed, one would see gradually evolving, reconfiguring architectures, based on coalitions of actors with common goals [10].

Consequently, the coordination of a large number of distributed decision makers could take place in qualitatively different ways from the traditional top-down hierarchical coordination based on temporal and spatial decomposition. Sensing, measurements, communications, and control structures are becoming multilayered and multidirectional, instead of being hierarchical. The electricity services of the future will be based on differentiable distributed performance metrics at a value which is likely to replace today's control area-wide reliability criteria [39], [61]. Similarly, the organizational changes themselves lead to distributed decision making and affect control areas' supply, delivery, and purchase of electricity services. Each functional/corporate entity has its own subobjectives. These subobjectives are attempted within a very uncertain system, since the rules for mandatory information exchange continue to remain quite vague.

A. Related Unconventional Requirements for Monitoring and Control

Managing multilayered architectures in future power grids will effectively require a framework for auto-reconfiguring electric power systems according to the changing needs of customers and system conditions. Auto-reconfiguring is to be done in an adaptive way so that the most is made out of the available resources. Adaptive management is in sharp contrast to today's top-down deterministic preventive control for managing uncertainties. Moreover, today the emphasis is on automation of local power grids (distribution systems) connecting

medium size and small residential users and not solely on the backbone transmission systems.

In order to meet these challenges, it is essential to develop a novel framework for dynamically integrating measurements and actuators throughout a large-scale network system in order to serve the end users efficiently during normal conditions, as well as reliably and securely during extreme conditions. Much intelligence needs to be developed for novel disruptive technologies, such as: 1) automatic metering of end users, digital relays; 2) flexible ac transmission systems (FACTS), which for all practical purposes could be viewed as fast electronic valves for switching the parameters of the wires so that the strength of the interconnection and the overall configuration are dynamically controlled; 3) small distributed generation, ranging from combined heat power (CHP) through wind, solar, and fuel cells, as well as a very large number of highly unconventional small energy sources; 4) sensors and actuators for automated control of demand by the end users, including their response to dynamic electricity prices; as well as 5) exploring the potential of sensors ranging from typical size, through nano- and microsensors, which could be placed, in particular, with the end user [5]. Model-based information and software algorithms will form the basis for coordinating interactions between these actively responding distributed components. Extensive simulations are needed to demonstrate the potential of just-in-time (JIT) and just-in-place (JIP) auto-reconfigurations of all candidate groups of components.

B. Dynamic Energy Control Protocols (DECPS) as a Possible Means for Coordinated Interactions Among Distributed Decision Makers

Conceptually, the envisioned DECPS would be embedded reconfigurable architectures facilitated by model-based interactive information systems for predictable performance at various industry layers of the changing industry [41], [42], [55], [56], [86]. Our research focuses on the conceptualization of such evolving system architectures, families of system models, and multilayered operating and planning decision solutions to support the reconfigurable power grids of the future. We view this task as a problem of designing and operating complex engineering systems by highly unconventional means.

A DECP framework is intended to integrate dynamically the measurements and actuators throughout a large-scale network system in order to serve the end users efficiently during normal conditions, and reliably and securely during extreme conditions. No single method lends itself to supporting such a framework. Instead, the envisioned auto-reconfiguration framework draws on several ideas: 1) making the system more observable by enhancing and gradually replacing current centralized supervisory data acquisition and control systems (SCADA) with multilayered measurement-communications

architectures; 2) making the system more controllable by enabling both end users and the network elements with actuators, in addition to establishing suppliers as the main decision makers; 3) programming the logic for dynamic adjustments of context-dependent performance objectives at various actuators and industry layers; 4) using the context-dependent performance objectives to aggregate dynamically the measurement and control information; and 5) developing a new generation software architecture for simulating and eventually implementing items 1) through 4).

Our basic approach rests on two ideas: first, one needs to introduce a family of models to be embedded at each (group of) component level to assist its sensors and actuators convert large amounts of data into relevant information, and to adjust the logic of the actuators over broad ranges of conditions. These models must capture the physical processes in sufficient detail. Their complexity and order vary dynamically as a function of the objectives for which they are used, and of the type of sensing and actuation available. These models help sensors select the key information. In addition, these models help actuators adjust their performance subobjectives and even regroup their subobjectives with the subobjectives of other actuators, depending on the overall system conditions. The second major idea is the system integration of the (groups of) components by designing an information-based DECP framework for iterative interactions among groups of components. The major challenge is how to provide feedback incentives among the groups of components to aggregate dynamically and decide between their own subobjectives and the objectives of the entire system. Novel concepts are needed for interactive model-supported sensing and decision making at the various industry layers. This plan should ultimately result in dynamically reconfigurable portions of the system according to their own subobjectives, and with as much consideration for the objectives of the entire system as possible. The ultimate result will be the automation of JIT and JIP electricity service for well-understood performance in a complex electric power grid or similar network infrastructure.

Attempting the above two ideas is far beyond the current state of the art in large-scale dynamic systems. We believe that what is needed, instead, are breakthroughs across modeling, sensing, estimation, control, supporting software, and communications. All of these areas require a fresh look prior to efforts to solve the problem at hand. We briefly explain in the remainder of this section both the current state-of-the-art and the new approach needed for each of these areas.

C. Interaction Variables-Based Modeling of Open Access Dynamic Energy Control Protocols (DECPs)

One possible modeling paradigm rests on the key observation that each physical component is enabled by its own embedded model of the environment, sensors,

communications support, and actuators. As such, it could sense system conditions on-line, and gather this information for future decisions concerning the state of the environment and for decisions to be made in such an environment. It could ultimately disconnect or reconnect itself from the environment by either coordinating this action with others or by simply taking this action by itself. The model of such an intelligent component depends on how much communication is available, what is being sensed, and the performance subobjectives to be met. Each (group of) components J is characterized by its internal states x_{LC}^J and the interaction variables y_{LC}^J introduced earlier in the paper in the context of today's hierarchical control. The interaction variables are multidirectional heterogeneous exchanges between the component and the rest of the environment and from the environment to the component. A further generalized notion and mathematical definition of an interaction variable between a component and the environment is a generalization of the interaction variables underlying the hierarchical modeling of electric power systems. Fundamentally, the interaction variable between the component J and the environment is a combination of the internal states of component J , which can only be affected by direct interactions with the environment.

An autonomously reconfigurable system of the future is simply an interconnection of many such (groups of) components as sketched in Fig. 5. Each component is characterized by its own internal states and interaction variables. While each component has its own primary subobjective, it is frequently grouped with several other components working toward a common subobjective within a larger system. Both the grouping rules and the targets for interactions variables $y_{LC}^{J,ref}$ could either be defined externally, as for example in hierarchically structured network systems according to network ownerships [28], [29], [31]; or they evolve in a bottom-up way through dynamic exchanges with others, as in the changing industry [3], [55], [56]. Once established, the aggregated group of components can be characterized by its internal states and the interaction variables with the rest of the environment.

Models of complex interconnected network systems, such as an electric power grid, must capture both the natural response of its components to various disturbances, but also the effects of the interactions between individual components and/or aggregated groups of components. These interactions are often the result of distributed sensing, estimation, actuation, and decision making based on these internalized models of the environment. Depending on how actively the information is provided and processed to different (groups of) components, the interactions are more or less predictable. In an environment in which there is much uncertainty, probabilistic models are essential. Interactions among (groups of) components can be captured

using probabilistic models that define transitional probabilities about the behavior of other groups of components in the rest of the system [5]. Each (group of) components makes its own decisions with some confidence, depending on the level of information exchange with the rest of the system, the sensing of the system state, the use of prior knowledge, and the decision making logic for implementing its decisions.

D. Design of Reconfigurable Dynamic Energy Control Protocols (DECPs)

A fresh look into the architecture of an electric power network in which any (group of) components becomes an active decision maker affecting the interactions of the interconnected system in many novel ways suggests major complexities and possibilities for hard-to-predict emerging behavior. At least conceptually, it is impossible in such a complex environment to preserve today's hierarchical operating or planning practices. As pointed out earlier, the model of hierarchical decision makers does not lend itself to a system in which there is much action at the end user and network levels. Moreover, it is impossible to rely solely on the asynchronous interactions of various (groups of) components without any additional coordination.

One possible paradigm would be to design protocols for dynamic interactions between such (groups of) components, and for dynamic regrouping over time as system conditions vary. We conjecture that if protocols are model-based and specified using a modeling approach which draws on generalized interaction variables between different layers of the system, it would be possible to provide coordination for the system as a whole. One first example of such a protocol for the changing electric power industry can be found in [40]. Similar to the interplay of the routing layer and TCPs, a two-level interaction between the transmission provider and the end users of electricity was proposed as a possible means of managing transmission grid congestion through a two-way iterative interactions process. This example highlights the need for consistent performance objectives and iterative information exchange.

While achievable, the guiding rules for the DECPs should be designed to induce incentives for internalizing the interactions with the other members of the environment [5], [25]. A qualitatively different equilibrium may be reached through such interactions as groups of components follow their own subobjectives. The outcomes depend greatly on the rate and type of information exchanged. At least in principle, a small DG, such as CHP plants, could help serve local customers, and could also reconfigure their connections with the end users to supply some of them during extreme conditions, while reducing the consumption of the local end users. The problem is its integration through incentives. One needs to consider the design of the incentives for inducing the distributed groups

of decision makers to respond to the needs of the rest of the system, while attempting its own subobjectives to be one of the major open research problems of future power grids. The interaction variables-based modeling combined with the stochastic decision making under uncertainties could be used to induce such incentives [25]. Our conjecture is that correct information about the others could serve to provide indirectly these incentives by enabling the distributed decision makers to model the behavior of the others with a certain confidence. We already have preliminary simulations demonstrating that this is an approach in the right direction [46]. This is not a novel idea. However, what is very novel is the idea for each decision maker to sense the type of conditions, select the simplest model, out of a family of models/data available at its level, which is sufficiently accurate for representing interactions with the rest of the system for those likely conditions, and then adjust its subobjectives given this information.

Finally, we point out that the notion of heterogeneous interaction variables offers new possibilities for modeling, monitoring, and control of coupled technical, economic, and policy feed-forward and feedback signals. In particular, the designs of well-behaving evolving electricity markets require a dynamic view of the interaction variables [5], [10], [21], [47], [81]. For a detailed mathematical treatment of distributed decision makers in the changing electricity industry, see [47].

IX. CONCLUSIONS

In today's electric power industry there exists a genuine bias toward ensuring reliability through robust design, instead of relying on JIT and JIP scheduling and feedback. This is in part due to the overall overwhelming complexity of the problem which is at least twofold. More obvious is the problem of dealing with a high number of decisions and large networks. The less obvious and often hidden contributors to complexity are problems related to the emerging, hard-to-predict behaviors of these systems.

In the past, modeling and control have been pursued using strong assumptions which help simplify the complexity related to the sheer size of the problem. These efforts have been quite successful and form the basis of today's SCADA systems and hierarchical control for normal operations. In order to review the models used and to assess the assumptions and their contextual use, we have formalized more complex models and stated the assumptions leading to the currently used models. In particular, the class of models for hierarchical automatic generation control (AGC) in the United States and automatic voltage control (AVC) in Europe has been presented, which defined these engineering schemes using systems control approaches. In the later parts of this paper we have returned to the second class of complexities related to emerging behaviors in electric power systems

when they are operated outside of the normal operating regions; this can occur either during abnormal technical conditions caused by large equipment failures, or as a result of changing the decision making from hierarchical to open-access paradigms of the future.

While the two operating modes, hierarchical and open access, are qualitatively different in their complexity, we approach both paradigms by recognizing the underlying structures in these systems. We suggest that much depends on the dynamics, monitoring, and control of the interaction variables between different levels of the system, be it hierarchical or open access. Ultimately, a context-dependent dynamic aggregation could be arranged to induce the desired behavior of the interaction variables. In the hierarchical paradigm the monitoring and control structure is for fixed performance objectives. These are attempted through a design which supports the necessary assumptions. The evolving open-access future paradigm allows for a truly dynamic interplay between performance objectives, sensing, monitoring, control, and coordination. Finally, the open-access paradigm is probabilistic in its basic nature. Its success depends on aligning uncertainties with the right industry levels and on the adequate

management of interactions under uncertainties. Monitoring and control design play fundamental roles in how these uncertainties are aligned to provide the right incentives.

It is essential for academia to work closely with its industry partners, and to begin transforming both the backbone and local distribution electric power networks into future systems equipped with sufficient intelligence to sense what is most relevant, to convey this information to actuators for adjusting their performance objectives and logic, and/or to combine it further with the objectives of other actuators. We view these as the basic requirements for engineering electricity services of the future. The ultimate aim is to introduce model-based decision logic at the various layers of the distribution systems, and to simulate the performance of future automated distribution grids with options to choose between distributed generation, price responsive demand, and dynamic islanding of customers with special needs, a system capable of responding to attacks on both hardware and software. The vision is to demonstrate that an electric power grid can be both efficient and robust if and only if it dynamically adjusts to changes. ■

REFERENCES

- [1] D. Acemoglu and A. Ozdaglar, "Competition and efficiency in congested markets," *Math. Oper. Res.*, 2007.
- [2] E. H. Allen and M. Ilić, "Interaction of transmission network and load phasor dynamics in electric power systems," *IEEE Trans. Circuits Systems I: Fundam. Theory Appl.*, vol. 47, no. 11, pp. 1613–1620, Nov. 2000.
- [3] A. Armbruster and M. Gosnell, "Power transmission control using max-flow," in *Proc. 29th Annu. Int. Computers Software and Applications Conf.*, B. McMillin and M. Crow, Eds., 2005, pp. 256–263.
- [4] R. C. Armstrong and E. J. Moniz, *Report of the Energy Research Council*. Cambridge, MA: Mass. Inst. Technol., 2007.
- [5] M. Aoki, *New Approaches to Macroeconomic Modeling: Evolutionary Stochastic Dynamics, Multiple Equilibria, and Externalities as Field Effects*. Cambridge, U.K.: Cambridge Univ. Press, 1996.
- [6] A. Bensoussan, "Singular perturbation results for a class of stochastic control problems," *IEEE Trans. Autom. Control*, vol. AC-26, no. 5, pp. 1071–1080, Oct. 1981.
- [7] D. Bertsekas, G. Lauer, N. Sandell, and T. Posbergh, "Optimal short-term scheduling of large-scale power systems," *IEEE Trans. Autom. Control*, vol. AC-28, no. 1, pp. 1–11, Jan. 1983.
- [8] A. Carpasso, E. Mariani, and C. Sabelli, "On the objective functions for reactive power optimization," presented at the IEEE Winter Power Meeting, 1980, paper A 80 090-1.
- [9] N. Cohn, "Research opportunities in the control of bulk power and energy transfers on interconnected systems," in *Special Report on Power System Planning and Operations: Future Problems and Research Needs*, EPRI EL-377-SR, Feb. 1977.
- [10] J. Contreras and F. F. Wu, "Coalition formation in transmission expansion planning," *IEEE Trans. Power Syst.*, vol. 14, no. 3, pp. 1144–1152, Aug. 1999.
- [11] M. L. Crow and M. Ilić, "Effects of system decomposition and waveform relaxation windowing on the efficiency of large scale power systems simulation," in *Proc. of the 12th IMACS World Congress on Scientific Computation*, Paris, France, Jul. 1988.
- [12] C. L. DeMarco and J. Wassner, "A generalized eigenvalue perturbation approach to coherency," Dept. Elect. Comput. Eng., Univ. Wisconsin-Madison, Madison, WI, Tech. Rep. ECE-95-5, 1995.
- [13] C. A. Desoer and E. S. Kuh, *Basic Circuit Theory*. New York: McGraw-Hill, 1969.
- [14] A. K. Dixit and R. S. Pindyck, *Investments Under Uncertainty*. New York: Princeton Univ. Press, 1994.
- [15] I. Dobson and L. Lu, "Voltage collapse precipitated by the immediate change in stability when generator reactive power limits are encountered," *IEEE Trans. Circuits Syst. I, Reg. Papers*, vol. 39, no. 9, pp. 762–766, Sep. 1992.
- [16] T. E. Dy Liacco, "The adaptive reliability control system," *IEEE Trans. Power App. Syst.*, vol. PAS-86, no. 5, pp. 517–531, May 1967.
- [17] IEEE Committee Report, "Excitation system models for power system stability studies," *IEEE Trans. Power App. Syst.*, vol. PAS-100, no. 2, pp. 494–509, Feb. 1981.
- [18] FERC World Wide Web Site. [Online]. Available: <http://www.ferc.fed.us>
- [19] L. H. Fink and I. Erkmann, "Economic dispatch to match actual data to the actual problem," presented at the EPRI 1987 Power Plant Performance and Monitoring and System Dispatch Conf., EPRI CS/EL-5251-SR, pp. 4/23-43.
- [20] L. H. Fink, "Concerning power systems control structures," *ISA Adv. Instrum.*, vol. 26, pt. 1, pp. 1/1–1/11, 1971.
- [21] X. Guan, Q. Zhai, and F. Lai, "A new Lagrangian relaxation based algorithm for resource scheduling with homogenous subproblems," *J. Optimizat. Theory Appl.*, vol. 113, no. 1, pp. 65–82, Apr. 2002.
- [22] A. H. Haddad and P. V. Kokotović, "Stochastic control of linear singularly perturbed systems," *IEEE Trans. Autom. Control*, vol. AC-22, no. 5, pp. 815–821, Oct. 1977.
- [23] H. Happ, "Diakoptics and piecewise methods," *IEEE Trans. Power App. Syst.*, vol. PAS-89, no. 7, pp. 1373–1382, Sep. 1970.
- [24] R. Hardiman, M. Kumbale, and Y. Makarov, "An advanced tool for analyzing multiple cascading failures," presented at the Conf. Probabilistic Methods Applied to Power Systems (PMAPS), Ames, IA, 2004.
- [25] Y. C. Ho, P. B. Luh, and G. J. Olsder, "Incentive coordination and parallel algorithm," *IEEE Trans. Autom. Control*, vol. AC-26, no. 2, pp. 454–460, Apr. 1981.
- [26] IEEE Committee Report, "Dynamic models for steam and hydro turbines in power system studies," *IEEE Trans. Power App. Systems*, vol. PAS-92, no. 6, pp. 1904–1915, Dec. 1973.
- [27] IBM Intelligent Utility Network. [Online]. Available: <http://www.ibm.com/podcasts/howitworks/>
- [28] M. D. Ilić and S. X. Liu, *Hierarchical Power Systems Control: Its Value in a Changing Electric Power Industry*, ser. London Limited Series, Advances in Industrial Control. New York: Springer-Verlag, 1996.
- [29] M. D. Ilić and J. Zaborszky, *Dynamics and Control of Large Electric Power Systems*. New York: Wiley Interscience, 2000.
- [30] M. Ilić, F. D. Galiana, and L. Fink, Eds. *Electric Power Systems Restructuring: Engineering and Economics*. Boston, MA: Kluwer, 1998.

- [31] M. Ilić, S. X. Liu, B. D. Eidson, C. Vialas, and M. Athans, "A new structure-based approach to the modeling and control of electric power systems in response to slow reactive power/voltage load variations," *IFAC Automatica*, vol. 33, pp. 515–531, Mar. 1997.
- [32] M. Ilić-Spong, I. N. Katz, H. Dai, and J. Zaborszky, "Block diagonal dominance for system of nonlinear equations with application to load flow calculations in power systems," *Math. Modeling*, vol. 5, pp. 275–297, 1984.
- [33] M. Ilić, X. Liu, G. Leung, and M. Athans, "Improved secondary and new tertiary voltage control," presented at the IEEE Winter Power Meeting, Paper 95 WM 137-0 PWRs.
- [34] M. Ilić-Spong, M. Spong, and R. Fischl, "The no-gain theorem and localized response for the decoupled P-O network with active power losses included," *IEEE Trans. Circuits Syst.*, vol. CAS-32, no. 2, pp. 170–177, Feb. 1985.
- [35] M. Ilić, J. Thorp, and M. Spong, "Localized response performance of the decoupled Q-V network," *IEEE Trans. Circuits Syst.*, vol. CAS-33, no. 3, pp. 316–322, Mar. 1986.
- [36] M. Ilić and S. X. Liu, "A simple structural approach to modeling and analysis of the inter-area dynamics of the large electric power systems: Part I—Linearized models of frequency dynamics," in *Proc. 1993 North Amer. Power Symp.*, pp. 560–569.
- [37] M. Ilić and S. X. Liu, "A simple structural approach to modeling and analysis of the inter-area dynamics of the large electric power systems: Part II—Nonlinear models of frequency and voltage dynamics," in *Proc. North Amer. Power Symp.*, 1993, pp. 570–578.
- [38] M. D. Ilić and S. X. Liu, "Direct control of inter-area dynamics in large power systems using flexible ac transmission systems (FACTS) technology," U.S. Patent 5 517 422, 1996.
- [39] M. Ilić, J. R. Arce, Y. Yoon, and E. Fumagali, "Assessing reliability in the new environment," *Elect. J.*, pp. 55–67, Mar. 2001.
- [40] M. Ilić, E. Hsieh, and P. Ramanan, "Pricing of distributed multilateral energy transactions to ensure system security and guide economic dispatch," *IEEE Trans., Power Syst.*, vol. 18, no. 2, pp. 428–434, May 2003.
- [41] M. Ilić, "Model-based protocols for the changing electric power industry," presented at the Power Systems Computation Conf., Seville, Spain, 2002.
- [42] M. Ilić, "Toward a multi-layered architecture of large-scale complex systems: Reliable and efficient man-made infrastructures," presented at the MIT/ESD Symp., Cambridge, MA, 2004.
- [43] M. Ilić, "Automating operation of large electric power systems over broad ranges of supply/demand and equipment status," in *Applied Mathematics for Restructured Electric Power Systems*, J. Chow, F. Wu, and J. Momoh, Eds. Norwell, MA: Springer, ch. 6, pp. 105–137.
- [44] M. Ilić, E. Allen, J. Chapman, C. King, J. Lang, and E. Litvinov, "Preventing future blackouts by means of enhanced electric power systems control: From complexity to order," *Proc. IEEE*, vol. 93, no. 11, pp. 1920–1941, Nov. 2005.
- [45] M. Ilić, J. Lang, X. Luo, and E. Litvinov, "The critical role of computationally robust optimal AC power flow in reliable and efficient voltage/reactive power dispatch," presented at the 2006 Power Systems Conf. Expo, Atlanta, GA.
- [46] M. Ilić, E. Hsieh, and P. Ramanan, "Pricing of distributed multilateral energy transactions to ensure system security and guide economic dispatch," *IEEE Trans. Power Syst.*, vol. 18, no. 2, pp. 428–434, May 2003.
- [47] M. Ilić, *Engineering Electricity Services of the Future*. New York: Springer-Verlag, 2007.
- [48] H. Khalil and Z. Gajić, "Near-optimum regulators for stochastic linear singularly perturbed systems," *IEEE Trans. Autom. Control*, vol. AC-29, no. 6, pp. 531–541, Jun. 1984.
- [49] C. A. King, J. W. Chapman, and M. D. Ilić, "Feedback linearizing excitation control on a full-scale power system model," *IEEE Trans. Power Syst.*, vol. 9, no. 2, pp. 1102–1111, May 1994.
- [50] G. Kron, *Diakoptics—The Piecewise Solution of Large-Scale Systems*. London, U.K.: Macdonald, 1963.
- [51] P. Kundur, *Power Systems Stability and Control*. New York: McGraw Hill, Inc.
- [52] F. K. Mak and M. D. Ilić, "Classification of voltage problems in electric power systems," *Int. J. Elect. Power Energy Syst.*, vol. 15, pp. 377–385, Apr. 1993.
- [53] R. Marceau, R. Malihot, and F. Galiana, "A generalized shell for dynamic security analysis in operations planning," *IEEE Trans. Power Systems*, vol. 8, no. 3, pp. 1099–1106, Aug. 1993.
- [54] J. Medanić, M. D. Ilić, and J. Christensen, "Discrete models of slow voltage dynamics for under load tap-changing transformer coordination," *IEEE Trans. Power Systems*, vol. PWRs-2, no. 4, pp. 873–882, 1987.
- [55] K. Moslehi, A. B. R. Kumar, D. Shurtleff, M. Lauefenberg, A. Bose, and P. Hirsch, "Framework for a self-healing power grid," presented at the IEEE PES General Meeting, San Francisco, CA, 2005.
- [56] K. Moslehi, R. A. Kumar, E. Dehdasthi, P. Hirsch, and W. Wu, *Distributed Autonomous Real-Time System for Power System Operations—A Conceptual Overview*, 2004.
- [57] North American Electric Reliability Co. (NERC). [Online]. Available: <http://www.nerc.com>
- [58] M. A. Pai, *Energy Function Analysis for Power System Stability*. New York: Kluwer, 1989, pp. 145–164.
- [59] J. P. Paul, J. Y. Leost, and J. M. Tesseron, "Survey of the secondary voltage control in France," *IEEE Trans. Power Syst.*, vol. PWRs-2, no. 2, pp. 505–511, May 1987.
- [60] R. Podmore, "Identification of coherent generators for dynamic equivalents," *IEEE Trans. Power App. Syst.*, vol. PAS-97, no. 4, pp. 1344–1354, Jul./Aug. 1978.
- [61] J. F. Prada and M. D. Ilić, "Pricing reliability: A probabilistic approach," *Energetica*, vol. 23, pp. 75–89, Jul. 2000.
- [62] A. G. Phadke and J. S. Thorp, *Computer Relaying for Power Systems*. New York: Wiley, 1988.
- [63] S. J. Rassenti, V. L. Smith, and B. J. Wilson, "Controlling market power and price spikes in electricity markets: Demand-side bidding," *Proc. Nat. Acad. Sci.*, vol. 100, pp. 2998–3003, 2003.
- [64] D. W. Ross and S. Kim, "Dynamic economic dispatch of generation," *IEEE Trans. Power App. Syst.*, vol. PAS-99, no. 6, pp. 2060–2068, Nov./Dec. 1980.
- [65] R. Saeks and R. DeCarlo, *Interconnected Dynamical Systems*. New York: Marcel Dekker, 1981.
- [66] P. W. Sauer and M. A. Pai, "Modeling and simulation of multimachine power dynamics," in *Advances in Control and Dynamic Systems*, C. T. Leondes, Ed., New York: Academic, 1991, vol. 43.
- [67] F. C. Schweppe et al., "Homeostatic utility control," *IEEE Trans. Power Apparatus and Systems*, vol. PAS-99, May/June. 1980.
- [68] B. Stott, "Review of load-flow calculation methods," *Proc. IEEE*, vol. 62, no. 7, pp. 916–929, Jul. 1974.
- [69] D. Siljak, *Large-Scale Dynamic Systems*. New York: Elsevier North-Holland, 1978.
- [70] R. F. Sincovec, A. M. Erisman, E. L. Yip, and M. A. Epton, "Analysis of descriptor systems using numerical algorithms," *IEEE Trans. Autom. Control*, vol. AC-26, no. 1, pp. 139–147, Feb. 1981.
- [71] S. Talukdar and F. F. Wu, "Computer-aided dispatch for electric power systems," *Proc. IEEE*, vol. 69, no. 10, pp. 1212–1231, Oct. 1981.
- [72] J. S. Thorp, M. Ilić-Spong, and M. Varghese, "An optimal secondary voltage-var control technique," *IFAC Automatica*, vol. 22, pp. 217–221, 1986.
- [73] L. S. Van Slyck, N. Jaleeli, and W. R. Kelley, "A comprehensive shakedown of an automatic generation control process," *IEEE Trans. Power Syst.*, vol. 4, no. 2, pp. 771–781, May 1989.
- [74] U.S. Federal Energy Regulatory Commission (FERC), Rule 888, 1996.
- [75] U.S. Department of Energy Blackout Report. [Online]. Available: <http://www.doe.gov>
- [76] P. Varaiya, F. Wu, and H.-D. Chiang, *Bifurcation and Chaos in Power Systems: A Survey*, Memo. UCBER/L M90/98: Electronics Research Laboratory, Univ. California, Berkeley, CA, Aug. 1990.
- [77] V. Venkatasubramanian, H. Schättler, and J. Zaborszky, "Fast time varying phasor analysis in the balanced large electric power system," *IEEE Trans. Autom. Control*, vol. AC-22, no. 4, pp. 505–517, Aug. 1977.
- [78] V. Venkatasubramanian, H. Schättler, and J. Zaborszky, "A stability theory of large differential algebraic systems—A taxonomy," Rep. SSM 9201-Prt I, 1992.
- [79] P. Visudhiphan and M. Ilić, "A multi-agent approach to modeling electricity spot markets," presented at the IFAC Symp. Modeling and Control of Economic Systems, Klagenfurt, Austria, 2001.
- [80] L. Wehenkel, *Automatic Learning Techniques in Power Systems*. Norwell, MA: Kluwer, 1998.
- [81] K. P. Wong and J. Yuryevich, *Optimal Power Flow Method Using Evolutionary Programming, Lecture Notes in Artificial Intelligence*. New York: Springer-Verlag, 1998.
- [82] A. J. Wood and B. F. Wollenberg, *Power Generation, Operation, and Control*, 2nd ed., New York: Wiley, 1996.
- [83] F. F. Wu and R. L. Sullivan, "Nonlinear resistive circuit models for power system steady-state analysis," in *Proc. 14th Allerton Conf.*, Univ. Illinois, Urbana, IL, 1976, pp. 261–268.
- [84] F. F. Wu, "Diakoptics and triangular factorization," presented at the IEEE Power Engineering Society Winter Meeting, New York, 1975, paper C 75 107-8.
- [85] F. F. Wu, P. Varaiya, P. Spiller, and S. Oren, "Folk theorems and transmission open access: Proofs and counter examples," Univ. California Energy Inst., POWER Rep. PWR-23, Oct. 1994.

- [86] F. F. Wu, K. Moslehi, and A. Bose, "Power system control centers: Past, present, and future," *Proc. IEEE*, vol. 93, no. 11, pp. 1890–1909, Nov. 2005.
- [87] J. L. Wyatt, Jr., L. O. Chua, J. W. Gannett, I. C. Goknar, and D. N. Green, "Energy concepts in the state-space theory of nonlinear n-ports: Part I—Passivity," *IEEE Trans. Circuits Syst.*, vol. CAS-28, no. 1, pp. 48–61, Jan. 1981.
- [88] L. Xie, J. Ilić, and M. Ilić, "Towards grid modernization through enhanced communications and computing: Novel performance index and information structure for monitoring voltage problems," in *Proc. North Amer. Power Symp. (NAPS) 2006, Univ. Illinois*, pp. 667–674.
- [89] C. N. Yu, J.-P. Leotard, and M. Ilić, "Dynamic transmission provision in competitive electric power industry," in *Discrete Event Dynamic Systems: Theory and Applications*. Boston, MA: Kluwer, vol. 9, pp. 351–388.
- [90] J. Zaborszky and M. Ilić, "Exploring the potential of the all DC (ADC) bulk power systems," presented at the Bulk Power System Dynamics and Control V, Onomichi Japan, 2001, plenary paper.
- [91] J. Zaborszky and J. W. Rittenhouse, *Electric Power Transmission*. New York: Rensselaer Bookstore-Troy, 1969.
- [92] J. Zaborszky, "Some basic issues in voltage stability and viability," presented at the Bulk Power System Voltage Phenomena—Voltage Stability and Security, Potosi, MO, 1989.

ABOUT THE AUTHOR

Marija D. Ilić (Fellow, IEEE) received the M.Sc. and D.Sc. degrees in systems science and mathematics from Washington University, St. Louis, MO, and the Dipl.Ing. and M.E.E. degrees from the University of Belgrade, Yugoslavia.



She is a Professor in the Electrical and Computer Engineering and Engineering Public Policy Departments, Carnegie-Mellon University, Pittsburgh, PA. She was a Senior Research Scientist at the EECS Department at the Massachusetts Institute of Technology (MIT) since 1987, and currently holds an Appointment of a Research Affiliate in the Engineering Systems Division at MIT. From September 1999 until March 2001, she was a Program Director for Control, Networks and Computational Intelligence at the National Science Foundation. Prior to her years at MIT, she was on the faculty at the University of Illinois at Urbana-Champaign, Cornell University, Ithaca, NY, and Drexel University, Philadelphia, PA. She has coauthored several books on the subject of large-scale electric power systems: *Dynamics and Control of Large Electric Power Systems* (New York: Wiley, 2000); Ilić, Galiana, and Fink (eds.), *Power Systems Restructuring: Engineering and Economics* (Norwell, MA: Kluwer Academic, 2000); 2nd printing: *Price-Based Commitment Decisions in the Electricity Markets* (London, U.K.: Springer-Verlag, Ltd., 1999); *Hierarchical Power Systems Control: Its Value in a Changing Industry* (London, U.K.: Springer-Verlag, Ltd., 1996), and *Valuation, Hedging and Speculation in Competitive Electricity Markets: A Fundamental Approach* (Norwell, MA: Kluwer Academic, 2001). Her newest monograph is entitled *Engineering Electricity Services of the Future*, and is a result of collaborating with around 30 former and current students and colleagues (to be published by Springer in 2007). Her interest is in control and design of large-scale systems.

Dr. Ilić is a recipient of the First Presidential Young Investigator Award for Power Systems. She is an IEEE Distinguished Lecturer.