

Copyright And Fair Use

Enjoy Your Models

All images are copyrighted. Permission is granted **ONLY for non-commercial personal use**. They may not be duplicated in any form, including electronic, mechanical or printed, for sale. All rights are reserved and duplication by any means, including, but not limited to, methods of printing, electronic storage and disk copies, is prohibited without permission. If you wish to use this artwork and instructions for other than your own personal use, like for a club contest or school program, PLEASE contact me for written permission first.

You may NOT duplicate, sell, or give away, in any form, this file or printed copies of it.

Only the copyright owner, Phil Koopman, Jr. and/or **FLY'N THINGS™**, can give permission for copies to be made.

No Warranty is provided whatsoever.

This material is provided on an as-is basis with no support and no warranty.

Phil Koopman, Jr.
koopman@cmu.edu
<http://www.ece.cmu.edu/koopman>

Heir to the author:
Philip Koopman, Sr.

Lockheed's F117A Stealth Fighter

PAPER CARD MODEL

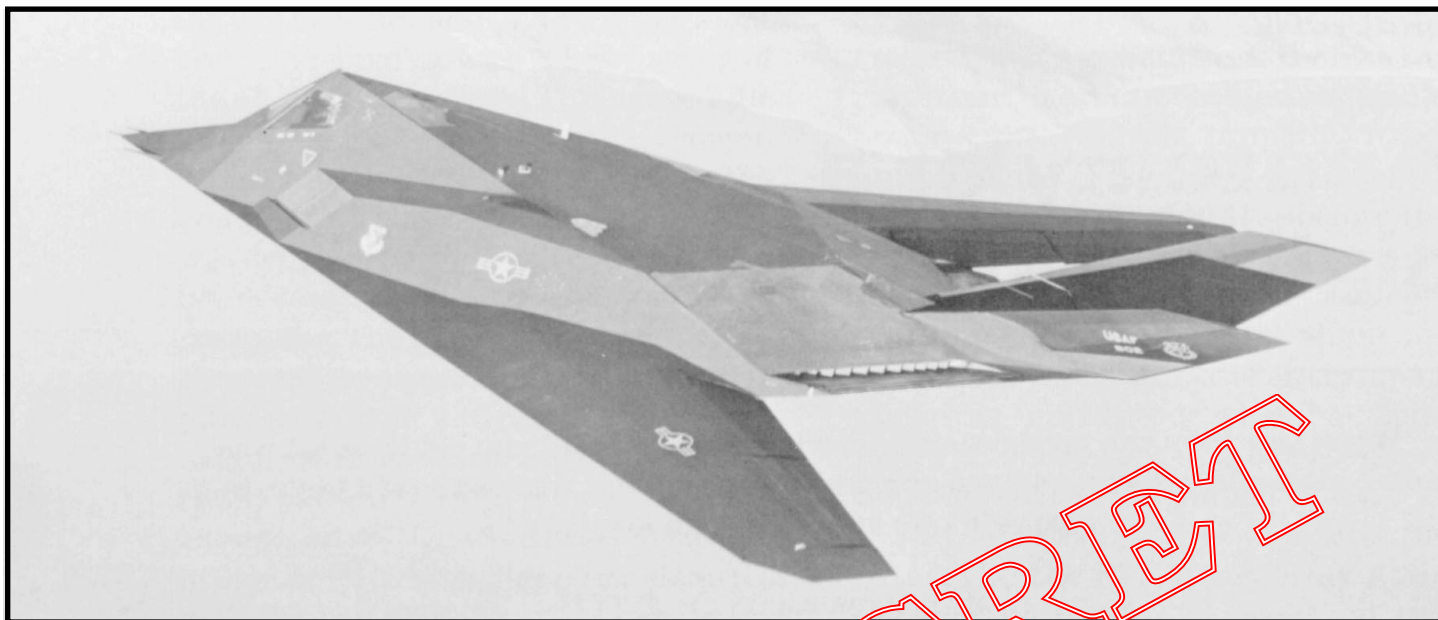

Official USAF Photograph

Once shrouded in secrecy, the F117A Stealth Fighter was officially unveiled by the United States Air Force in early 1990. This public display at Nellis Air Force Base, on April 21, 1990, showed a most-unusual aircraft. Instead of smooth, flowing curves, the F117A was dead black and all flat-plate angles — even its airfoil had the flat-plate construction. Definitely ugly, and certainly not aerodynamic like the sleek jet fighters one is used to seeing.

Lockheed created the F117A at its famous Skunk Works. Long known for special aircraft, like the U-2 and SR-71 spy planes, the talents of the Skunk Works designers turned to producing an aircraft invisible to Radar. This design has all flat surfaces, with all set at carefully calculated angles to each other. Each surface is designed to bounce off Radar beams at angles, much like one can reflect the sun with a mirror. Other parts of the plane's surface absorb the Radar signal. This makes the F117A invisible to Radar — if no signal is bounced back to the enemy Radar system's antenna, no detection is possible. Other *Stealth* tricks included shrouding the exhaust system to prevent Infra-Red (IR) detection of engine exhaust. And, the F117A doesn't carry Radar. The Radar signal would be picked up as it approaches. Instead, flight-path data are from an inertial-navigation system (INS) and IR detectors.

It's called a fighter, but the F117A is really a bomber. It is unarmed. The plane relies on its Stealth capability to approach and acquire a target, drop its ordnance and sneak away without detection. Its weapons system relies on Video/IR image data to guide smart bombs to their target. Target acquisition is from the nose-mounted Forward Looking Infra-Red (FLIR) system that projects a TV-like image for the pilot. A second system is mounted on the bottom of the F117A. This is the Downward-Looking Infra-Red (DLIR) system. Both systems are steerable, adjustable for wide- or narrow-angle view and can be used for flight or weapons guidance.

The F117A Stealth Fighter is rather large and carries just the pilot. The aircraft design required a computer-controlled flight system for stability. And, it's a true fly-by-wire system — pilot inputs are to a computer, not directly to the control surfaces. Generally accepted specifications are:

| | |
|----------|---|
| Wingspan | 43 Feet 4 Inches |
| Length | 65 Feet 11 Inches |
| Height | 12 Feet 5 Inches |
| Power | Two GE 10,600-lb Thrust F404-F1D2 Jet Engines |
| Speed | 646 MPH |
| Range | 1000 Miles - Extended Range With In-Flight Refueling |



Trim And Glue Strip To Back Of Seam
Cut Apart

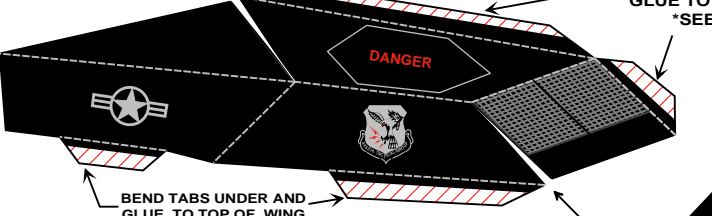

BEND TABS UNDER AND GLUE TO TOP OF WING
RIGHT SIDE JET INLET
Trim And Glue Strip To Back Of Seam
Cut Apart

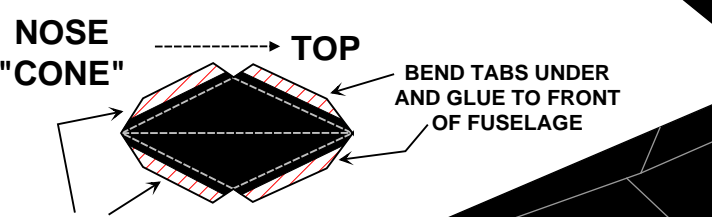

NOSE "CONE"
BEND TABS UNDER AND GLUE TO FRONT OF FUSELAGE
BEND TABS UNDER AND GLUE TO FRONT OF CENTER SECTION



NOSE GEAR & DOOR
MAKE FOUR PITOT TUBES FROM TOOTHPICKS
Trim And Glue Strip To Back Of Seam
Cut Apart

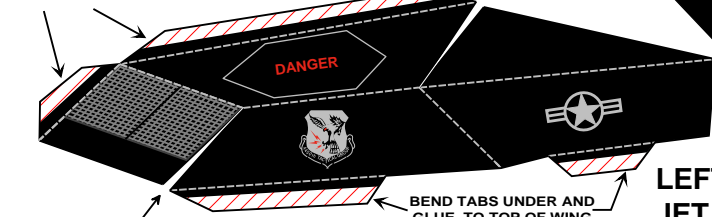

BEND TABS UNDER AND GLUE TO TOP OF WING
LEFT SIDE JET INLET
Cut Apart
Trim And Glue Strip To Back Of Seam

*NOTE: Experienced Builders Can Remove The Top Tabs Of The Jet Inlets
BEND TABS UNDER AND GLUE TO FUSELAGE *SEE NOTE

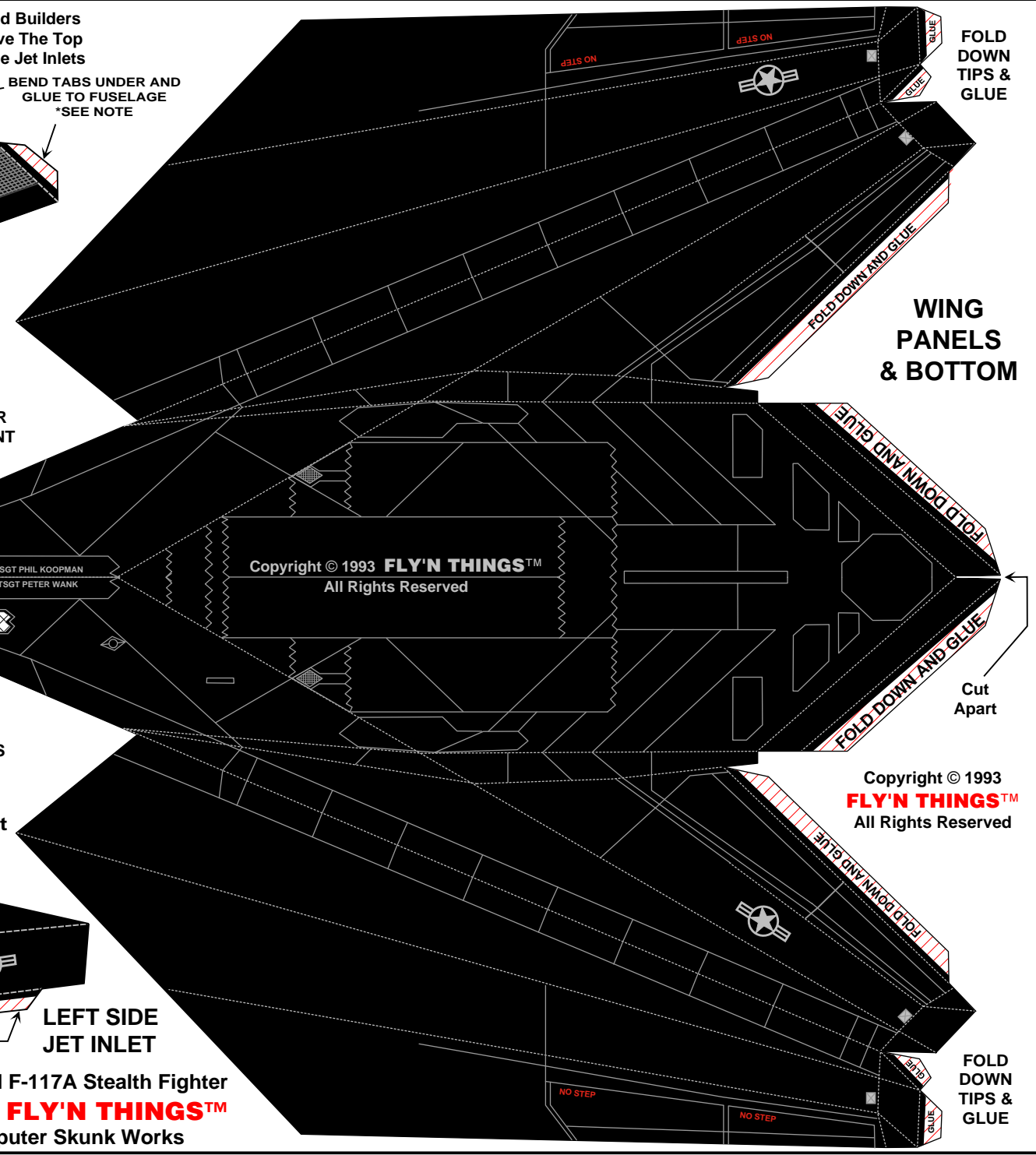

Lockheed F-117A Stealth Fighter
From The **FLY'N THINGS™**
Computer Skunk Works

Copyright © 1993
FLY'N THINGS™
All Rights Reserved



FLY'N THINGS™

Lockheed F-117A Stealth Building Instructions

1. You Will Need:



White Glue Or Household Cement

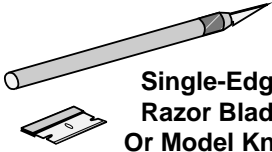

Single-Edge Razor Blade Or Model Knife

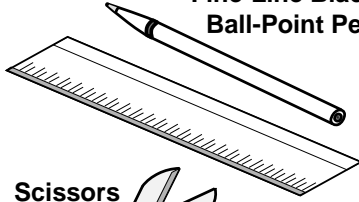

Score Folds With A Fine-Line Black Ball-Point Pen



Scissors

Metal-Edge Ruler Or Straight Edge

2. AND, Tape And A Cutting Board:

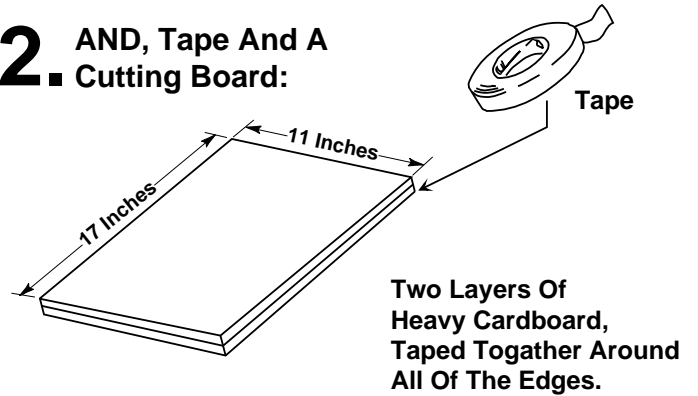

Two Layers Of Heavy Cardboard, Taped Together Around All Of The Edges.

3. Score Along All Dashed Lines Of Both Sheets With A Fine-Line Black Ball-Point Pen Or A Smooth-Edge Butter Knife.

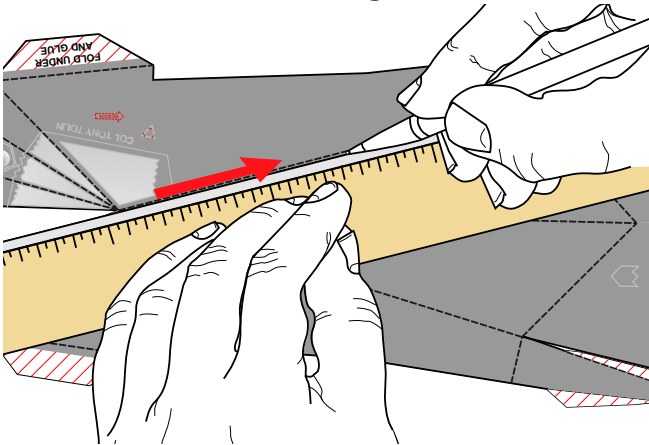

4. NEXT, Cut Along The Ends Of The Assembly Tabs With A Model Knife.

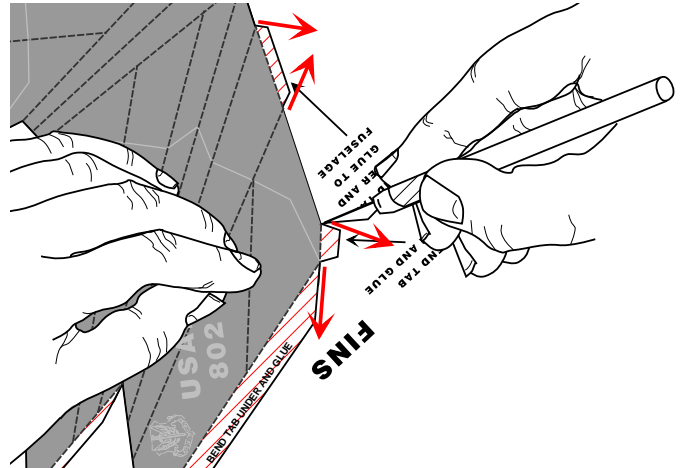

5. AND, Cut Open All V-Slits On Fuselage And Jet Inlets.

Make Straight Cuts Along Both Lines Marked *Cut Apart*.

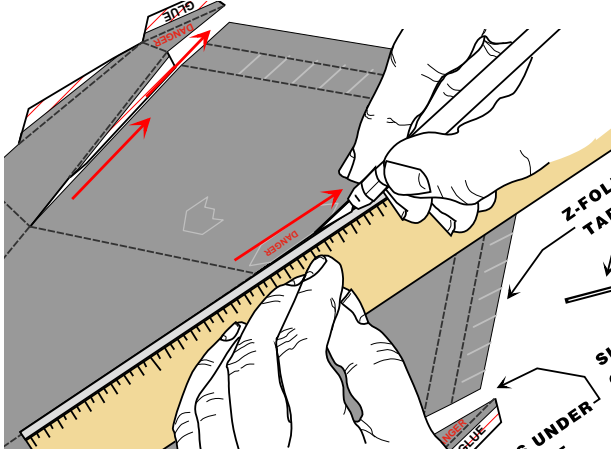

6. THEN, Cut Along The Black Outlines Between Tab Cuts. Finish By Cutting Parts Free Along Remaining Outlines.

Dashed-Line Arrows Are Prior Tab Cuts

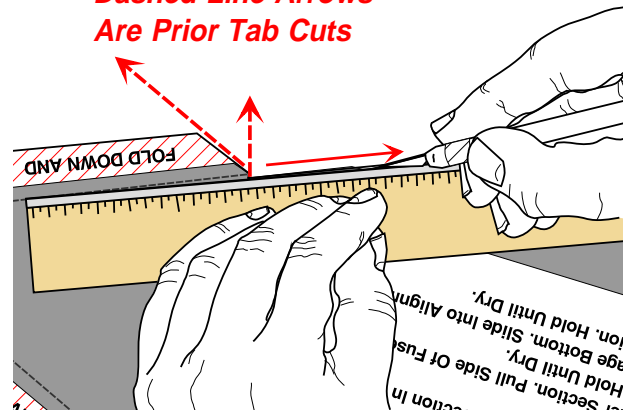

7. From The Printed Side, Fold Down On All Dashed Lines You Scored. Turn Over, Then ...

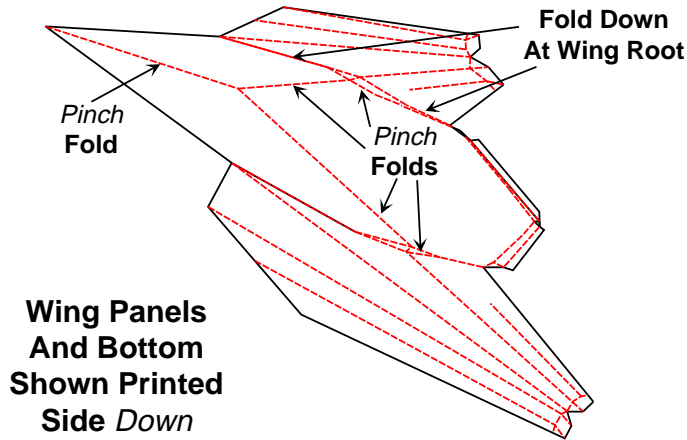

Wing Panels And Bottom Shown Printed Side Down

8. Fold Down All Tabs On The Center Section. Read Assembly Instructions!

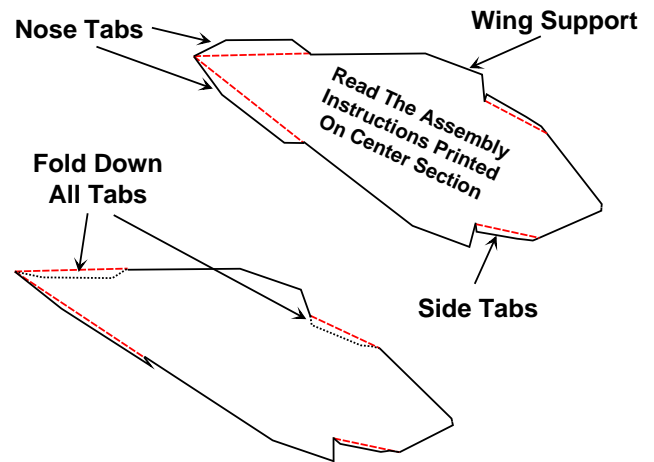

9. Glue The Center Section To The Bottom. Glue Nose, Wing Supports, Sides And Rear Bottom Tabs.

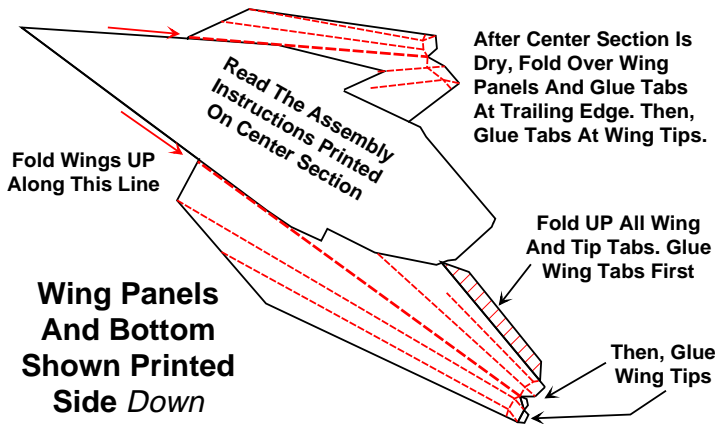

Wing Panels And Bottom Shown Printed Side Down

10. Assemble Fuselage Top. Glue Front Tab First. Pull Rear Seam Together And Glue Stiffener Underneath. Then, Glue Rear-Side Tabs.

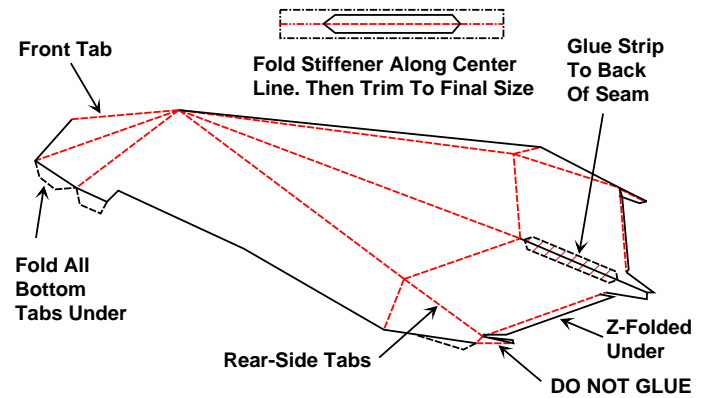

11. Next, Stiffen The Three Top Folds Of The Fuselage To Prevent Bending.

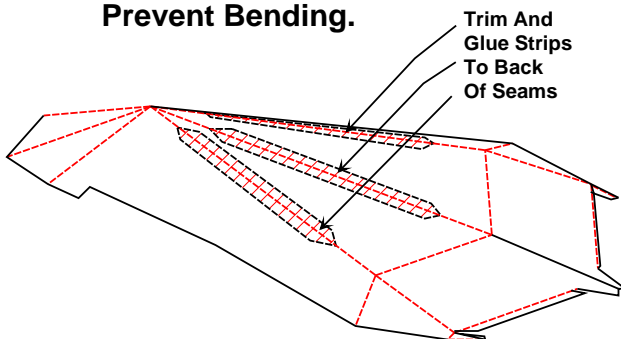

Fold Stiffeners Along Center Line. Then Trim To Final Size

12. Glue Completed Fuselage Top To The Bottom/Wing Assembly.

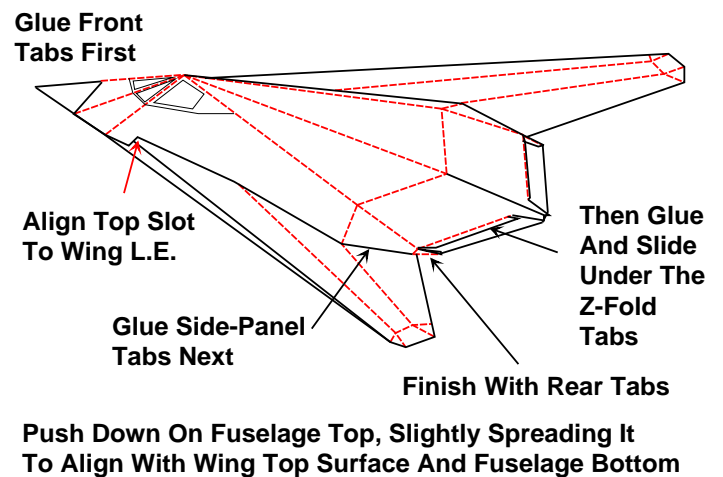

13. Assemble The Side Jet Inlets By Glueing Strips To The Back Of The Cut-Open Slits. Fold The Nose Piece Mark The Top On Back.

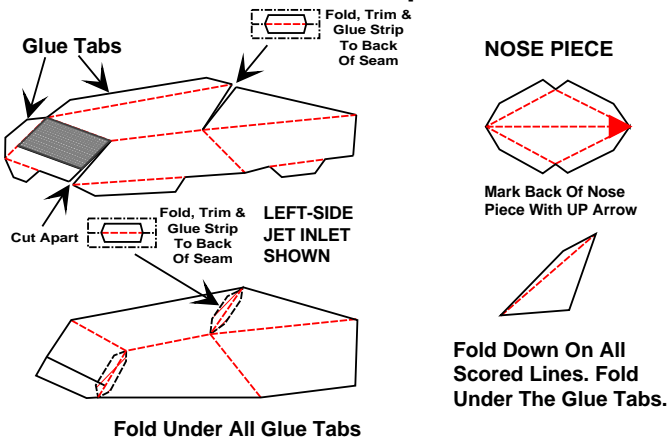

14. Glue The Nose Piece To The Front Of The Fuelage. Add The Left- And Right-Side Jet Air Inlets.

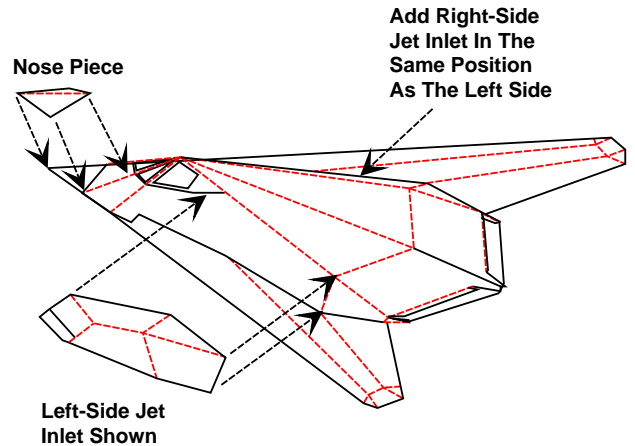

15. Fold Down On All Scored Lines. Fold Under The Glue Tabs. Glue The Rear Tabs First. Then, Glue The Tip And Bottom Tabs..

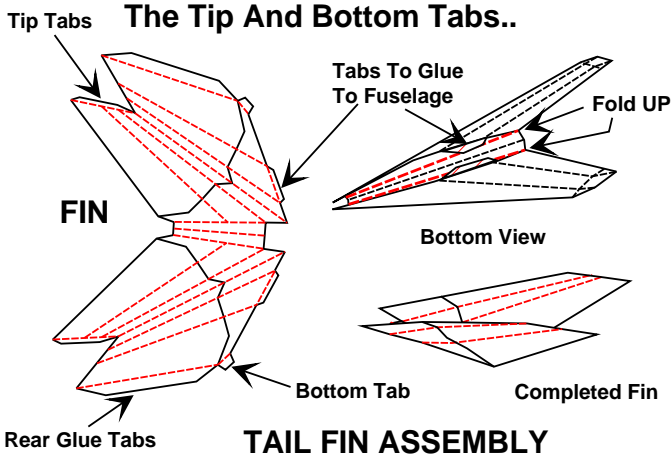

16. Finish By Glueing Fin Assembly In Place.

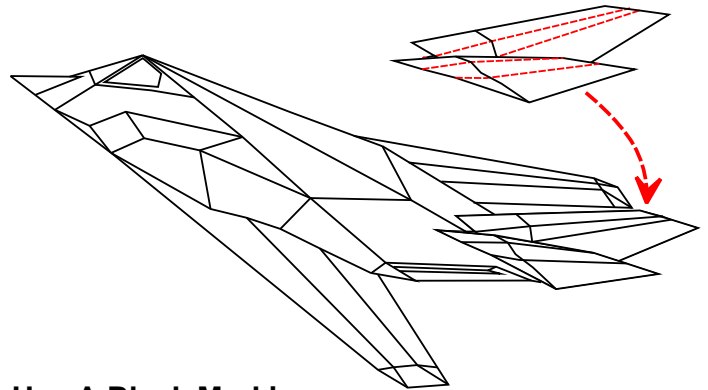

Use A Black Marking Pen To Cover All Exposed Paper Edges. Add Landing Gear If Desired (Steps 17 And 18).

17. Fold Landing-Gear Doors On Scored Line And Glue. Fold Landing Gear Struts Around A Toothpick And Glue.

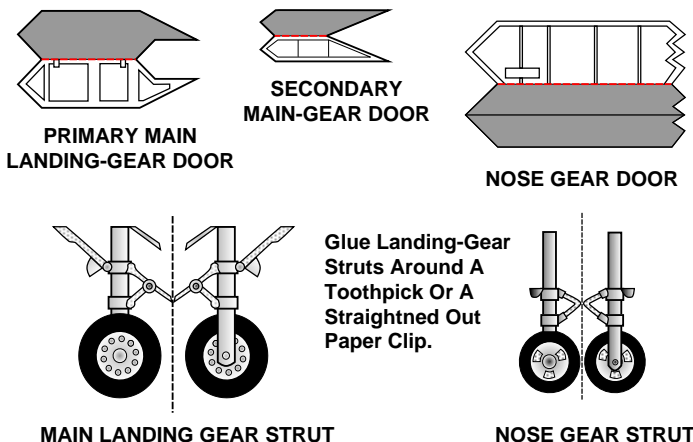

18. Push Toothpick Of Landing-Gear Struts Through Bottom And Center Section Of Fuselage. Glue, Add Doors.

