



Potential of FACTS and Flywheels for Transient Stabilization Against Large Wind Disturbances and Faults

Milos Cvetkovic and Kevin Bachovchin

mcvetkov@andrew.cmu.edu and kbachovc@andrew.cmu.edu

Joint work with
Prof. Marija Ilic
milic@ece.cmu.edu

8th Electricity Conference
Carnegie Mellon University
3/13/2012

Outline

- ❖ Transient stability problem in Flores Island power system
- ❖ Proposed solutions
 - Using FACTS as short-term energy storage
 - Using Flywheels as 'longer-term' energy storage
- ❖ Simulation results

Transient Stability Problems Due to Large Disturbances

❖ Types of large disturbances causing transient instabilities

- High wind surges in Flores Island
- Failures of equipment and faults

❖ Frequency instability

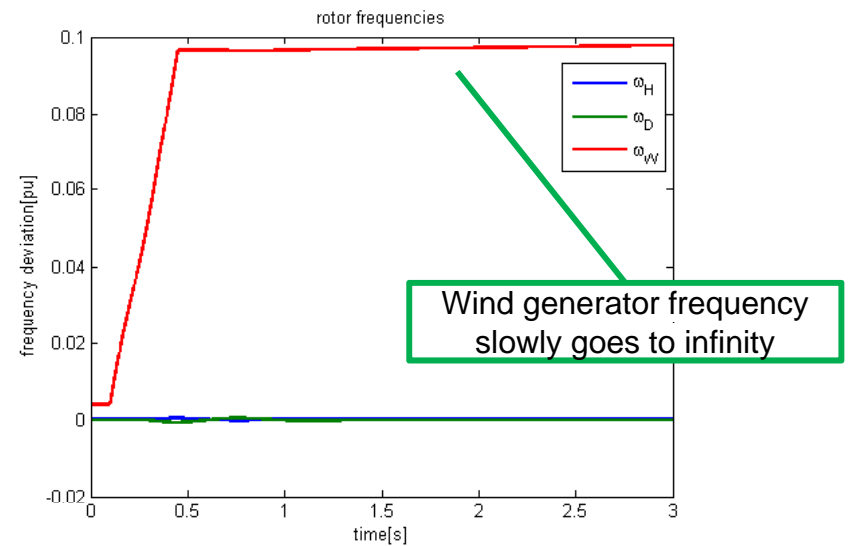
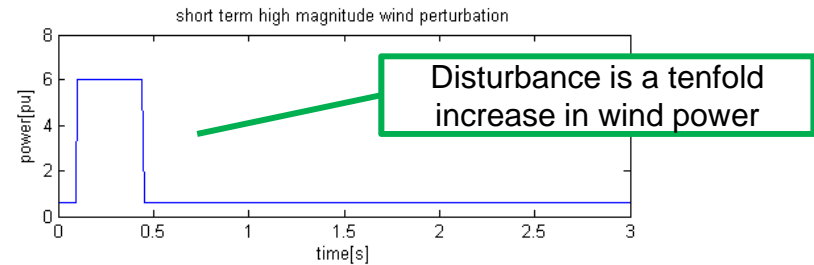
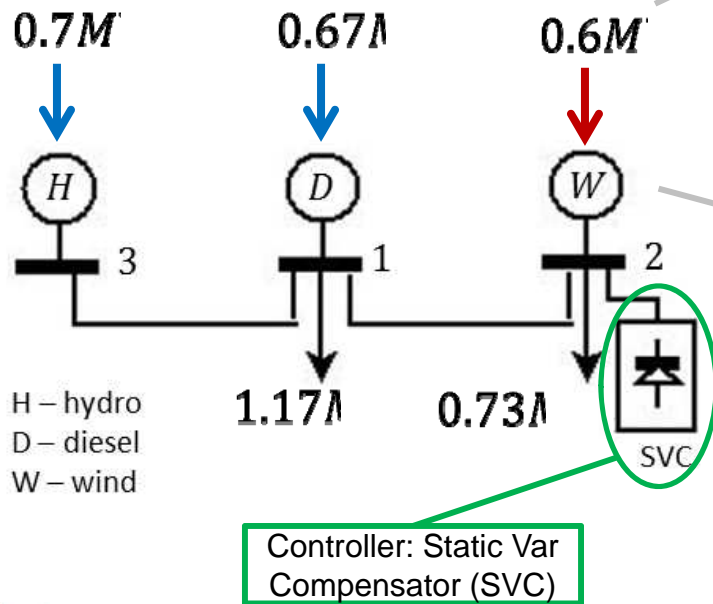

Transient Stabilization using FACTS

- ❖ Establish a *nonlinear model* which is relevant for representing large disturbances
- ❖ *Time-varying phasors* are used to model dynamics of generators and FACTS devices
- ❖ Nonlinear control is *energy-based*; energy function is expressed using time-varying phasors
- ❖ Energy function has a physical interpretation of *incremental accumulated (stored) energy* in the system
- ❖ *Controller shifts* the incremental stored energy between generators and FACTS devices

Time-Varying Phasor Model of FACTS (SVC)

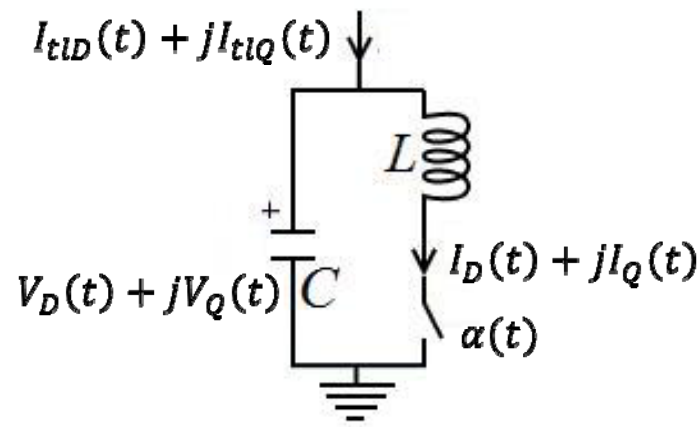

$$\dot{V}_D(t) = \frac{1}{C} (I_{tlD}(t) - I_D(t)) + \omega V_Q(t)$$

$$\dot{V}_Q(t) = \frac{1}{C} (I_{tlQ}(t) - I_Q(t)) - \omega V_D(t)$$

$$\dot{I}_D(t) = \frac{\alpha(t)}{L} V_D(t) + \omega I_Q(t)$$

$$\dot{I}_Q(t) = \frac{\alpha(t)}{L} V_Q(t) - \omega I_D(t)$$

- ❖ Time-varying phasors are used to model transmission lines and FACTS
 - Fast dynamics is captured
 - ODE model is established
- ❖ Assume fast thyristor switching – averaged switching model

Using FACTS Devices as Temporary Energy Storage

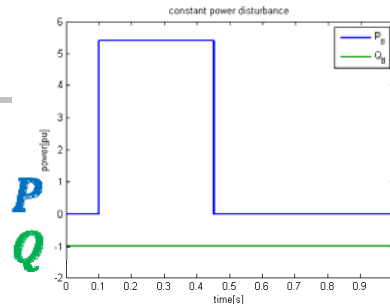
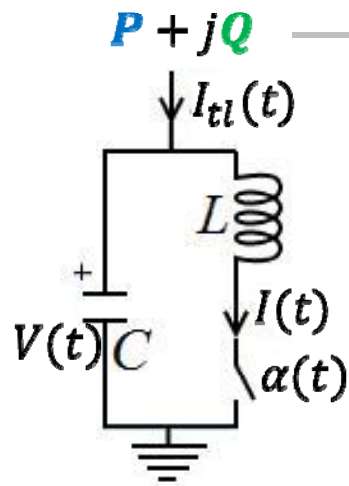

- ❖ Exploit the fact that reactive elements can accumulate active power during transients

Active power is different than zero on the average and it is equal to the size of the constant power disturbance P

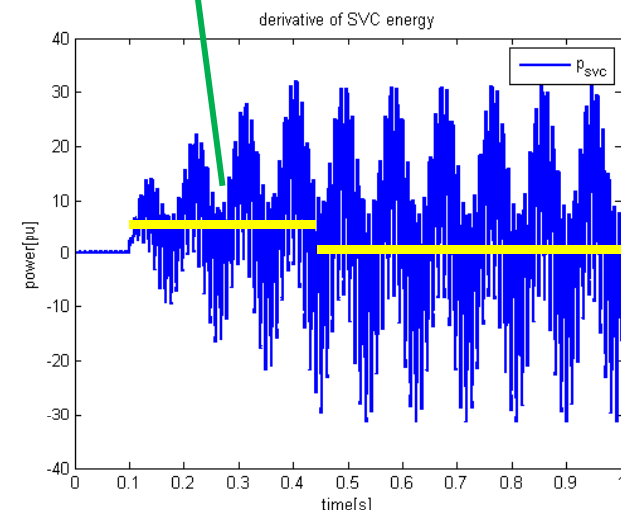
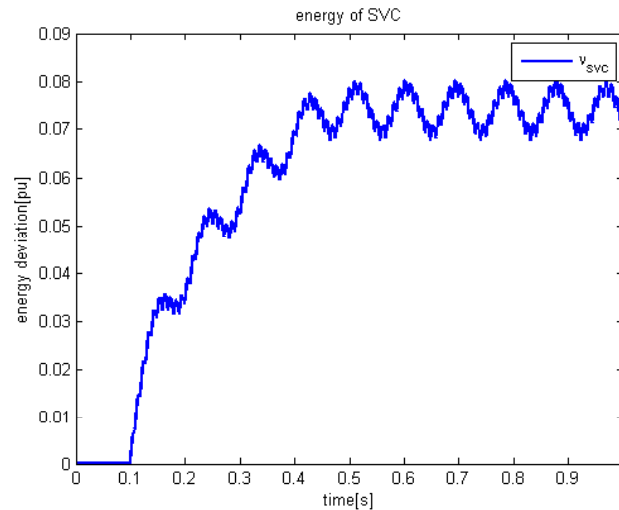

$$v(t) = \frac{1}{2} L \bar{I}^2(t) + \frac{1}{2} C \bar{V}^2(t)$$

$$p(t) = \frac{dv(t)}{dt} = L \bar{I}(t) \frac{d\bar{I}(t)}{dt} + C \bar{V}(t) \frac{d\bar{V}(t)}{dt}$$

$$P = \frac{1}{T} \int_0^T p(t) dt$$

Energy-based Control Law

$$v(t) = \sum_l v_{Cl}(t) + \sum_l v_{Ll}(t)$$

$$\dot{v}(t) = \dot{v}_{diss}(t) + \dot{v}_{exch}(t) + \dot{v}_{acc}(t)$$

$$e(t) = \dot{v}^{ref}(t) - \dot{v}_{acc}(t) = P^{ref}(t) - \dot{v}_{acc}(t)$$

$$\alpha(t) = K_p e(t) + K_I \int_0^t e(\tau) d\tau$$

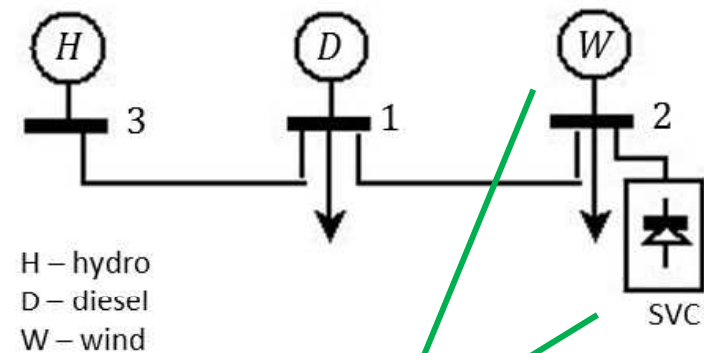

The biggest amounts of energy are accumulated in large inductors and capacitors

- ❖ Temporarily accumulates energy of a disturbance in FACTS devices [6].

Simulation Results

- Hydro
- Diesel
- Wind
- - - Uncontrolled system
- . - Other control strategies

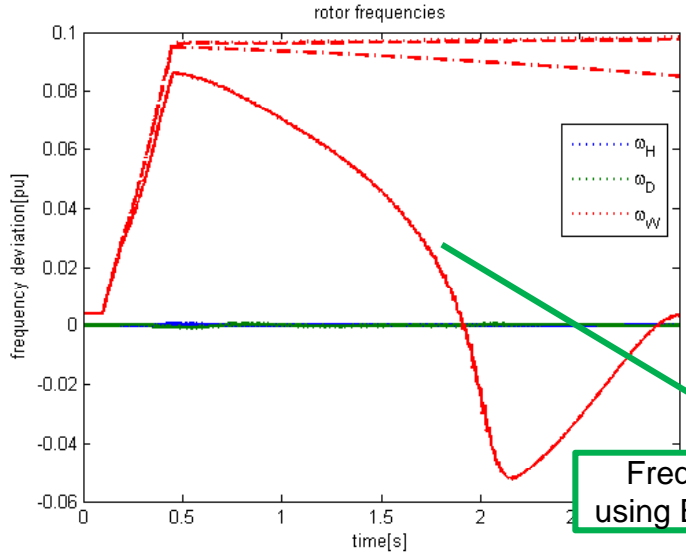

Total energy increment is minimized

Frequency is stabilized using Energy-based control

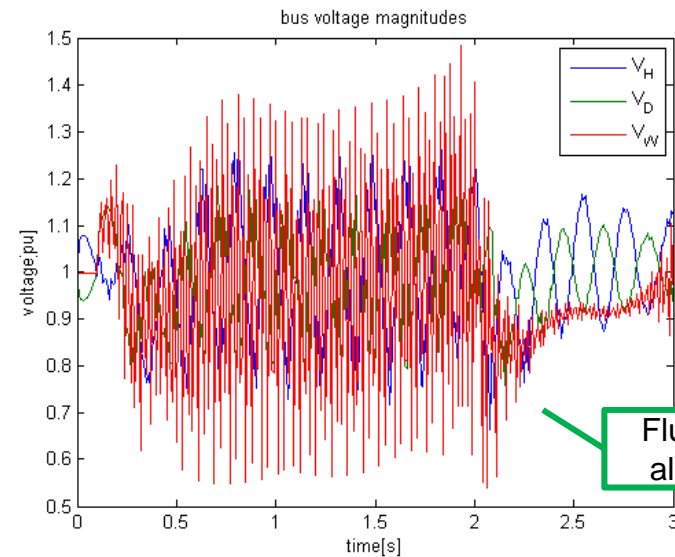
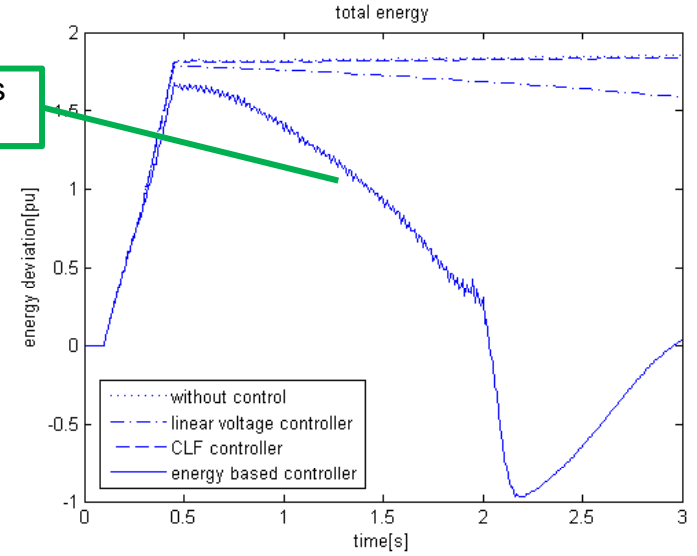

Fluctuations in SVC voltage allow energy accumulation

Energy stored in wires increases during transients

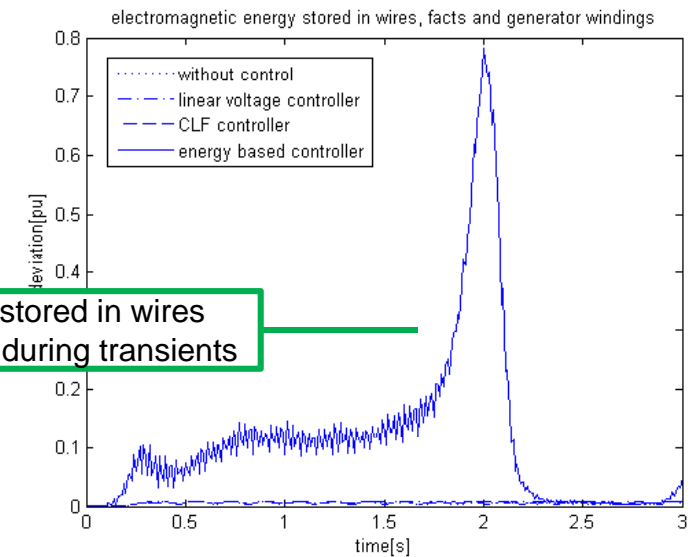

Transient Stabilization using Flywheels

- ❖ Introduce flywheels and their applications
- ❖ Sliding mode control
- ❖ Use flywheels in response to large wind disturbances when
 - Modeling the rest of the system as a disturbance
 - Modeling the dynamics of the rest of the system

Flywheel Energy Storage System

- ❖ Stores energy by accelerating a rotor to a very high speed
- ❖ Tensile strength of rotor material determines maximum capable stored energy
- ❖ Flywheel is connected to electric machine to control its rotational speed
- ❖ To decrease energy losses
 - Flywheel is operated in a vacuum
 - Magnetic bearings are used to levitate rotor [2],[3],[4]

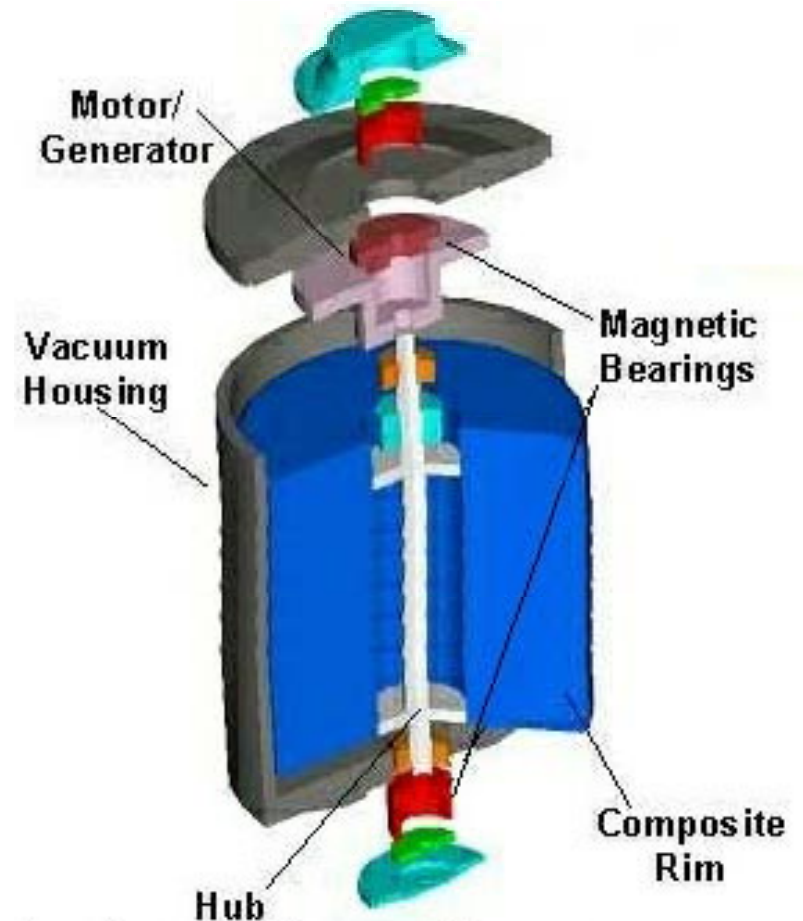

Potential Applications for Flywheels

- ❖ Flywheels have small time constants (compared to generators and alternative types of storage)
- ❖ Can be used for uninterruptible power supply, frequency stabilization, frequency regulation
- ❖ While FACTS devices can store active power only during transients, flywheels can store active power in steady state also
- ❖ Therefore, flywheels are more appropriate to use for prolonged disturbances

Dynamic Model of Flywheel

- ❖ When flywheel is connected to permanent magnet synchronous machine:
 - 3 state variables: ω_f, i_{qs}, i_{ds}
 - 2 input variables: v_{qs}, v_{ds}

$$\begin{aligned}\frac{N}{2} \lambda_m i_{qs} &= T_e = J \frac{d\omega_f}{dt} + D\omega_f \\ v_{qs} &= r_s i_{qs} + L \frac{di_{qs}}{dt} + \omega_f L i_{ds} + \omega_f \lambda_m \\ v_{ds} &= r_s i_{ds} + L \frac{di_{ds}}{dt} - \omega_f L i_{qs}\end{aligned} \quad [5]$$

Sliding Mode Control

- ❖ Drive i_{qs} and i_{ds} to desired values by fast switching of v_{qs} and v_{ds}

Switching Function

$$\begin{aligned} S_{ds} &= i_{ds}^* - i_{ds} \\ S_{qs} &= i_{qs}^* - i_{qs} \end{aligned}$$

Voltage Input

$$\begin{aligned} v_{ds} &= V_0 \text{sign}\{S_{ds}\} \\ v_{qs} &= V_0 \text{sign}\{S_{qs}\} \end{aligned}$$

Flywheel Power

$$\begin{aligned} P_f &= T_e \omega_f \\ P_f &= \frac{N}{2} \lambda_m i_{qs} \omega_f \end{aligned}$$

Response to Wind Disturbance

- ❖ Treat the rest of the system as a disturbance
- ❖ Set $i_{qs}^* = \frac{2\Delta P_{wind}}{N\lambda_m\omega_f}$, so flywheel absorbs wind disturbance

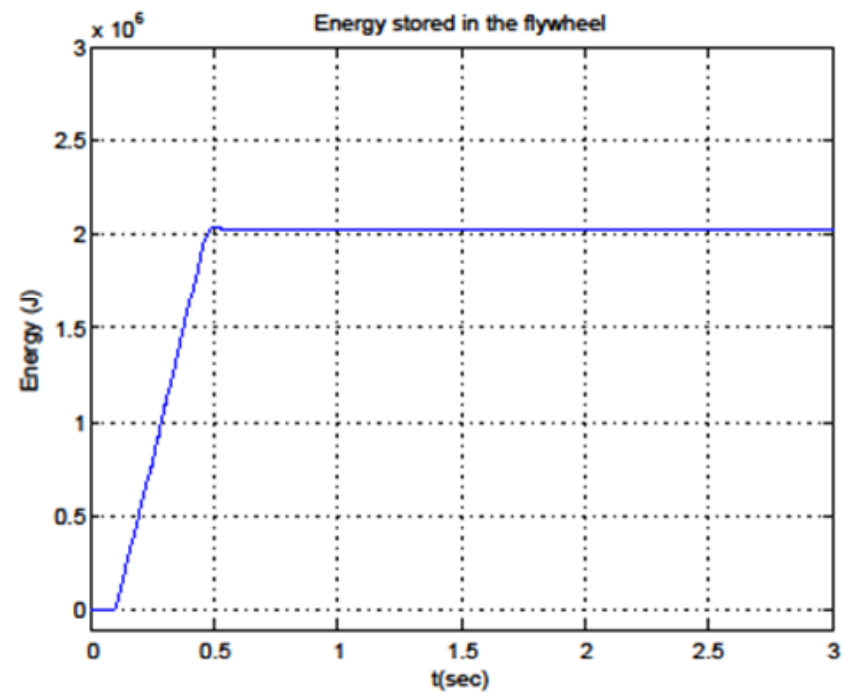
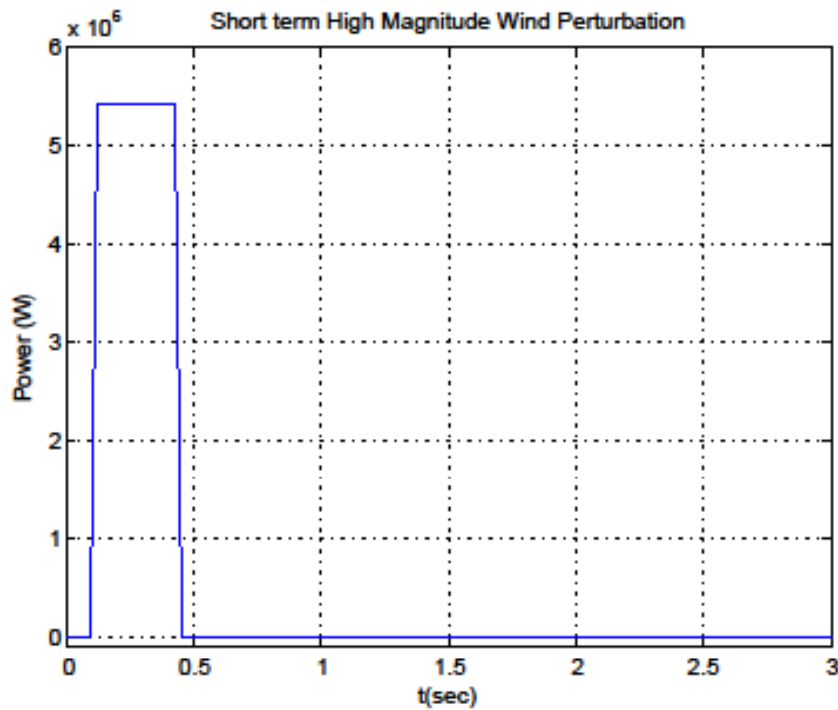

Dynamic Model of Flores Island Power System

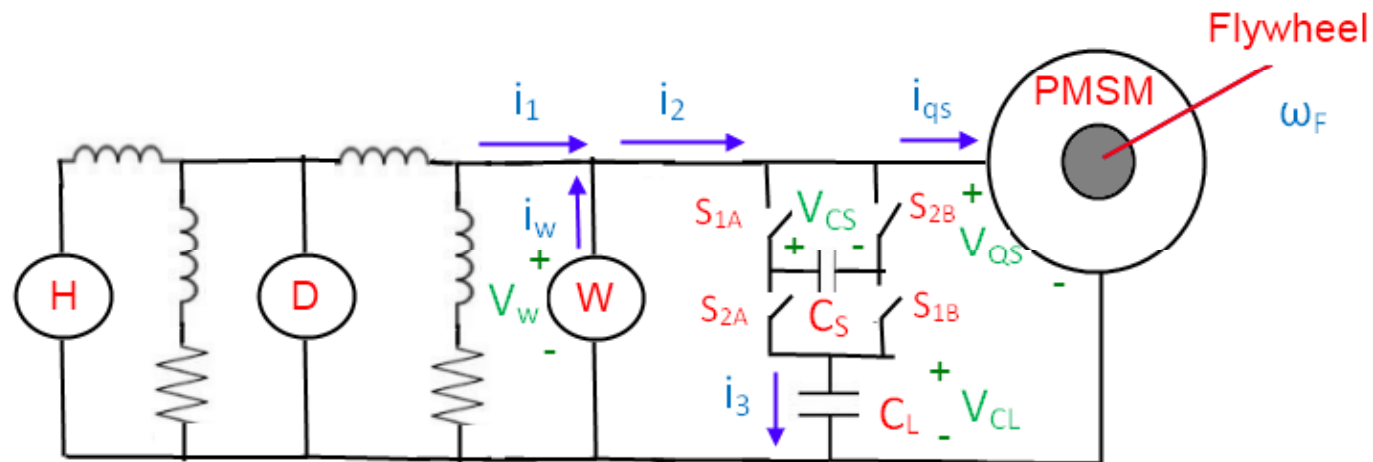

- ❖ Switches open and close at very high frequency relative to rest of the grid
- ❖ Large capacitor (C_L) serves to keep the voltage across the wind generator nearly constant
- ❖ The polarity of the small capacitor (C_s) changes to control i_{qs}

Use Flywheel for Frequency Stabilization

- ❖ Include dynamics of the entire system
- ❖ Set $i_{qs}^* = 0A$ in order to stabilize the disturbance

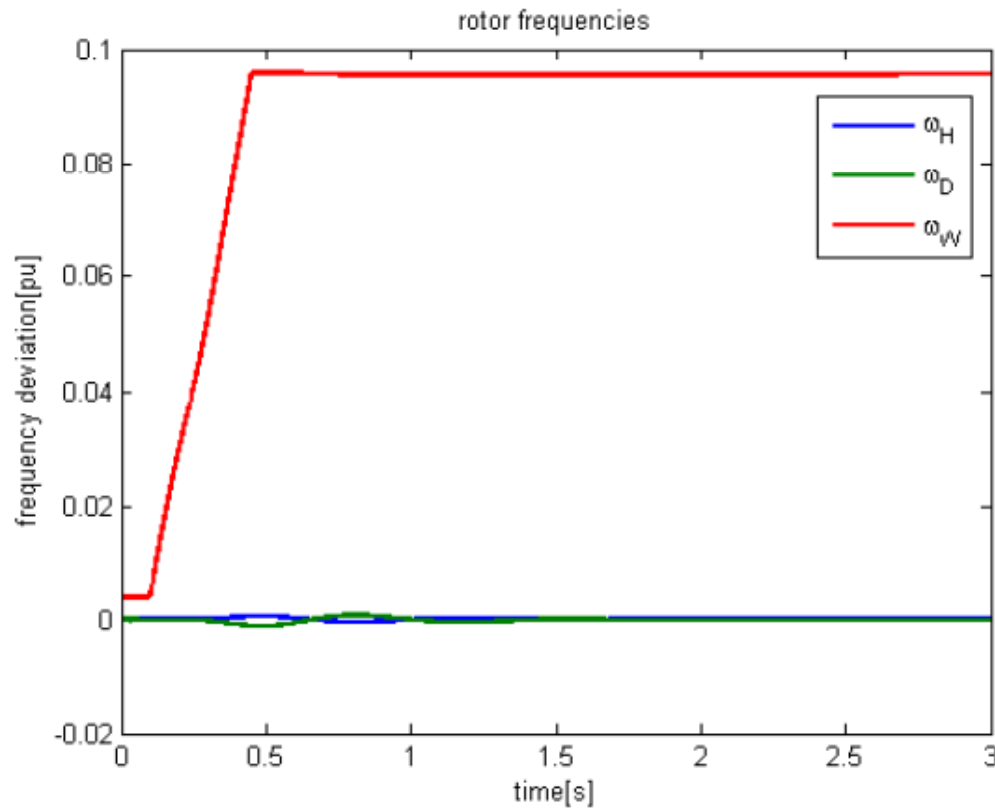

Conclusions

- ❖ Transient stability of Flores island has been improved using smart control on FACTS and flywheels
- ❖ While FACTS can store active power only for short time intervals, flywheels can be used for prolonged disturbances

Open Questions / Future Work

- ❖ Determining FACTS parameters based on stability requirements
- ❖ Larger power system with multiple flywheels
 - Multiple Input / Multiple Output Control
 - Decentralized or Cooperative Control?

References

- ❖ [0] “Engineering IT-Enabled Sustainable Electric Services: The Case of Low-Cost Azores Islands”, Springer, to appear in 2012
- ❖ [1] Flywheel energy storage Pictures, Flywheel energy storage Image, Science&Technology Photo Gallery. Feb 19, 2007. <<http://withfriendship.com/user/crook/flywheel-energy-storage.php> >
- ❖ [2] K. D. Bachovchin, “Magnetic Fields and Forces in an Ambient Temperature Passive Magnetically Levitated Bearing System”, M.S. dissertation, Carnegie Mellon University , PA, 2011. *
- ❖ [3] K. D. Bachovchin, J.F. Hoburg, R. F. Post, “Magnetic Fields and Forces in Permanent Magnet Levitated Bearings”, IEEE Transactions on Magnetics, [Accepted for Publication] *
- ❖ [4] K. D. Bachovchin, J.F. Hoburg, R. F. Post, “Stable Levitation of a Passive Magnetic Bearing”, IEEE Transactions on Magnetics, [Under Review] *
- ❖ [5] S. Talebi, B. Nikbakhtan, and H.A. Toliyat, “Analytical Model-Based Analysis of High-Speed Flywheel Energy Storage Systems for Pulsed Power Applications,” Proceedings of ESTS 2009, Baltimore, MD, April 20-22, 2009
- ❖ [6] M. Cvetkovic, M. Ilic, “PMU Based Transient Stabilization Using FACTS”, IEEE Power System Conference and Exposition, March 2011.

*Available at the request of the author