



18-899 Special Topics in Signal Processing



Multimedia Communications:
Coding, Systems, and Networking

Prof. Tsuhan Chen
tsuhan@ece.cmu.edu



Lecture 1

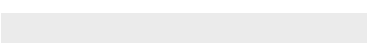

•
•
•
•
•
•
•
•
•
•

Fundamentals



•
•
•

What is Multimedia?

- **Multimedia**
 - Text, speech, music, audio, image, graphics, video, and many more...
- **Multimedia research**
 - Compression/Coding
 - Standards: H.series, MPEG, DAVIC, VRML...
 - Networking: streaming, QoS, VBR...
 - Implementation: architectures, low-power, MMX...
 - Databases: retrieval and indexing
 - Human-machine interface

18-899/Spring 1998/Chen

•
•

Multimedia Communications...

- Coding
 - Compression algorithms for audio, images, and video
- Systems
 - Integrating audio, video, and other components
- Networking
 - Transmission of multimedia over networks

18-899/Spring 1998/Chen

•
•

Images and Video

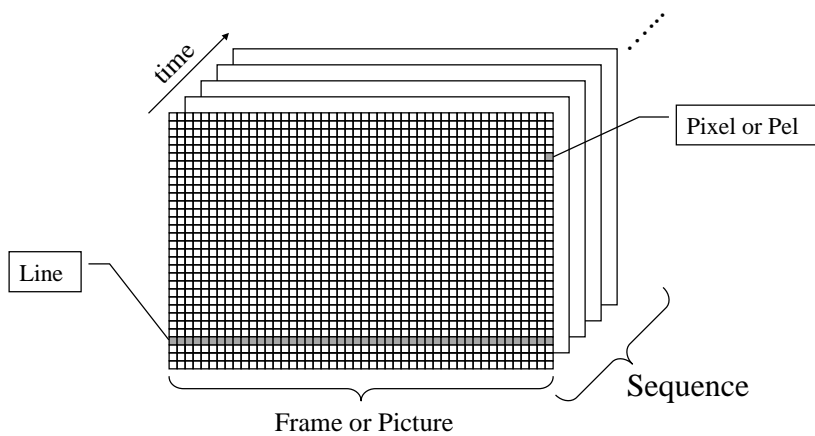

18-899/Spring 1998/Chen

Why Compression?

- Still images
 - $512 \times 512 \times 3$ bytes/pel = 6.29 Mbits
 - Needs 112 sec at 56 kbits/s

- Video

	Pels/line	Lines	Frames/s	Bytes/pel	Bit rate
Video Telephony (CIF)	352	288	10	1.5	12.2 Mbits/s
Broadcast TV (ITU-R 601 4:2:2)	720	480	30	2	166 Mbits/s
HDTV	~1280	~720	60	2	885 Mbits/s

18-899/Spring 1998/Chen

How to compress?

- Removal of statistical redundancy
 - Spatial redundancy: intra coding
 - Temporal redundancy: inter coding
 - Non-stationary statistics of images/video
- Human visual system
 - Spatial masking
 - Flat vs. texture areas
 - Temporal masking
 - Scene cuts
- Lossless compression vs. lossy compression

18-899/Spring 1998/Chen

⋮

Spatial Redundancy: Intra Coding

- Block-based schemes
 - Transform coding
 - Vector quantization (VQ)
- Non block-based schemes
 - Subband/Wavelet coding
 - Pyramid coding

18-899/Spring 1998/Chen

⋮

Block-Based Coding

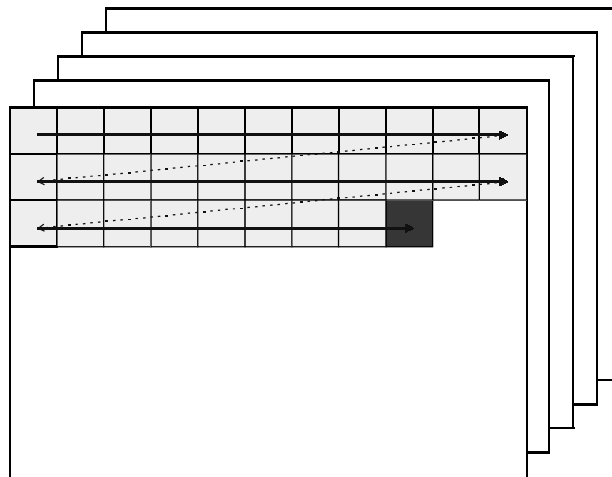

Typical block size: 8×8 or 16×16

18-899/Spring 1998/Chen

Transform Coding

Encoder

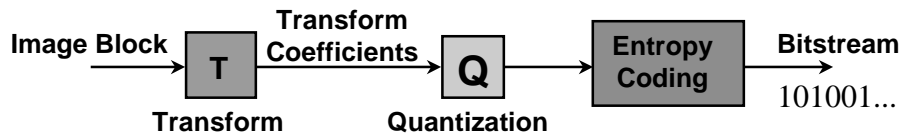

Decoder

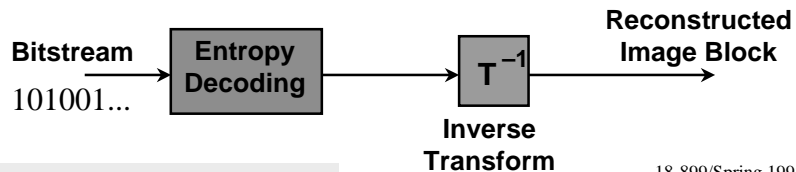

18-899/Spring 1998/Chen

Selection of Transform

- Decorrelation of transform coefficients
 - To remove redundancy
- Energy concentration
 - To allow selection of coefficients
 - Easy for entropy coding (cf. run-length coding)
- Discrete Cosine Transform (DCT)
 - Close to optimal for typical images
 - Well-known algorithm
 - Used in JPEG, H.26x, MPEG

18-899/Spring 1998/Chen

2D Discrete Cosine Transform

$$\begin{bmatrix} Y_{mn} \end{bmatrix} = \begin{bmatrix} C_{mn} \end{bmatrix}^T \begin{bmatrix} X_{mn} \end{bmatrix} \begin{bmatrix} C_{mn} \end{bmatrix}$$

Transform
Image
Coefficients
Block

- For 8x8 blocks

$$C_{mn} = k_n \cos \left[\frac{(2m+1)n\pi}{16} \right] \text{ where } k_n = \begin{cases} 1/(2\sqrt{2}) & \text{when } n = 0 \\ 1/2 & \text{otherwise} \end{cases}$$

- Question: Inverse DCT?

18-899/Spring 1998/Chen

Basis Vectors

0.35	0.35	0.35	0.35	0.35	0.35	0.35	0.35	→
0.49	0.42	0.28	0.10	-0.10	-0.28	-0.42	-0.49	→
0.46	0.19	-0.19	-0.46	-0.46	-0.19	0.19	0.46	→
0.42	-0.10	-0.49	-0.28	0.28	0.49	0.10	-0.42	→
0.35	-0.35	-0.35	0.35	0.35	-0.35	-0.35	0.35	→
0.28	-0.49	0.10	0.42	-0.42	-0.10	0.49	-0.28	→
0.19	-0.46	0.46	-0.19	-0.19	0.46	-0.46	0.19	→
0.10	-0.28	0.42	-0.49	0.49	-0.42	0.28	-0.10	→

18-899/Spring 1998/Chen

DC and AC Coefficients

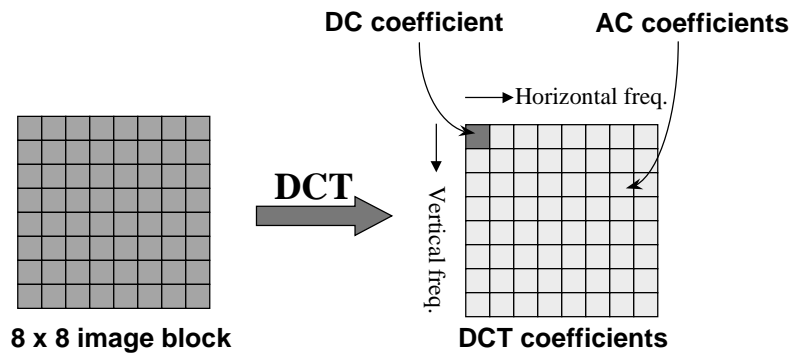

18-899/Spring 1998/Chen

Quantization

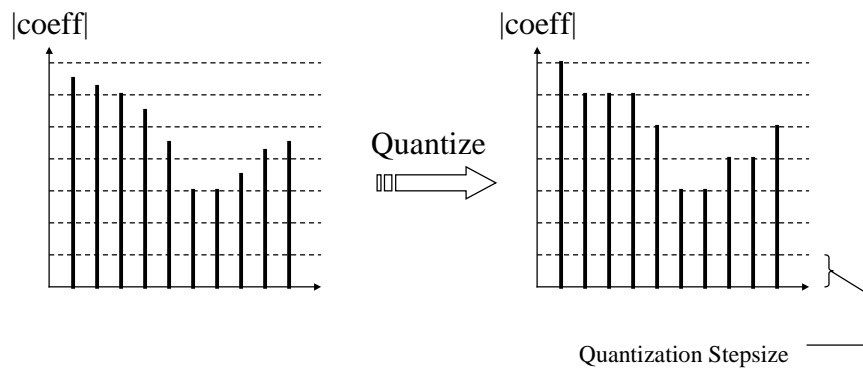

18-899/Spring 1998/Chen

An Example VLC...

Run	Level	Code
EOB		10
0	1	1s If first coefficient in block
0	1	11s Not first coefficient in block
0	2	0100 s
0	3	0010 1s
0	4	0000 110s
0	5	0010 0110 s
0	6	0010 0001 s
0	7	0000 0010 10s
0	8	0000 0001 1101 s
0	9	0000 0001 1000 s
0	10	0000 0001 0011 s
0	11	0000 0001 0000 s
0	12	0000 0000 1101 0s
0	13	0000 0000 1100 1s
0	14	0000 0000 1100 0s
0	15	0000 0000 1011 1s
1	1	011s
1	2	0001 10s
1	3	0010 0101 s
1	4	0000 0011 00s
1	5	0000 0001 1011 s
1	6	0000 0000 1011 0s
1	7	0000 0000 1010 1s
2	1	0101 s
2	2	0000 100s
2	3	0000 0010 11s
2	4	0000 0001 0100 s
2	5	0000 0000 1010 0s
3	1	0011 1s
...

0 0 0 -1 6 0 3 EOB



001111 001000010 001001010 10

18-899/Spring 1998/Chen

Temporal Redundancy: Inter Coding

- Conditional replenishment
 - Transmit only the changing blocks

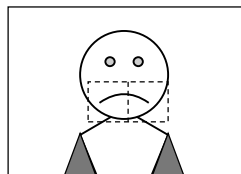

Previous Frame

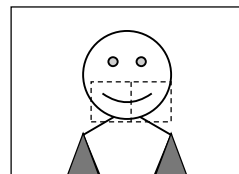

Current Frame

18-899/Spring 1998/Chen

Inter Coding (cont.)

- Motion

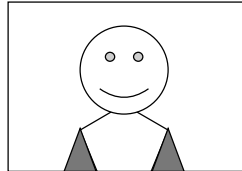

Previous Frame

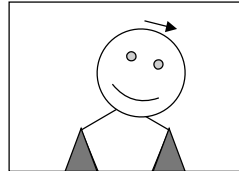

Current Frame

- Motion compensation

- Block-based motion
- Object-based motion
- Pel-based motion

18-899/Spring 1998/Chen

Block-based Motion Compensation

- Block matching for motion estimation (ME)

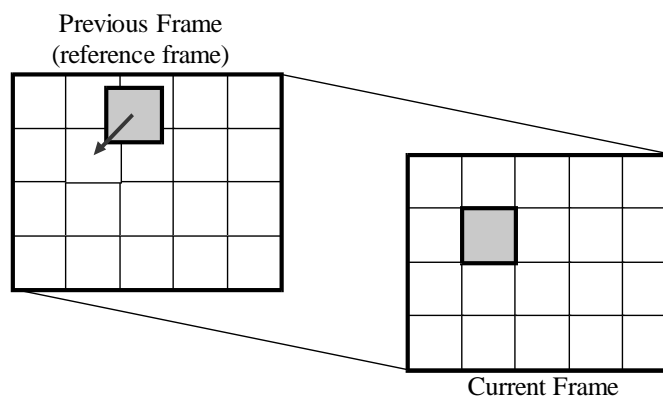

18-899/Spring 1998/Chen

Block-based Motion Compensation (cont.)

- Offset: motion vector
 - Differential coding in x
 - Differential coding in y
- Residue: prediction error
 - Coded as in intra coding

18-899/Spring 1998/Chen

Codec

- Encoder

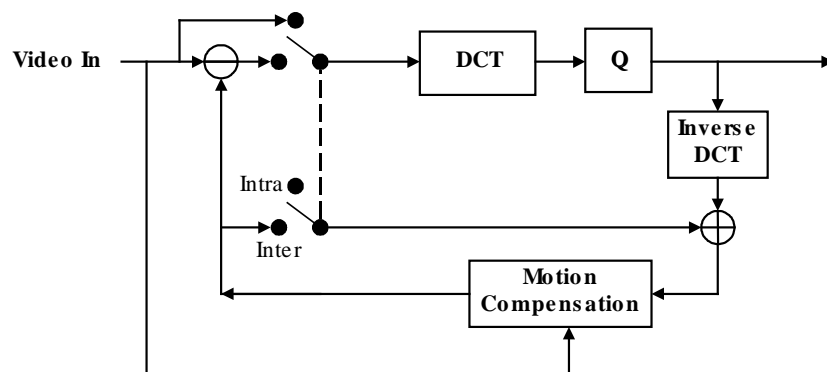

18-899/Spring 1998/Chen

Codec (cont.)

- Decoder

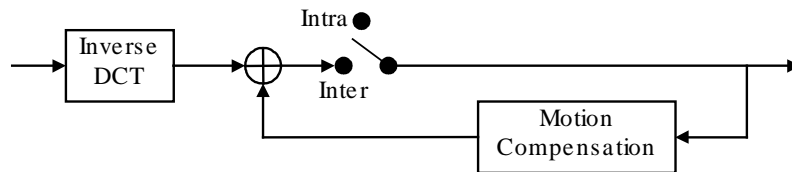

18-899/Spring 1998/Chen

International Standards



Why Standards?

- Important for communication
- Customers prefer standards to proprietary schemes: Freedom to choose
- Adoption of standards increases volume and brings down cost of
 - service providers
 - manufacturers
- Reduce the risk of deploying new technology
- Major players often participate
- Research opportunities

18-899/Spring 1998/Chen

Types of Standards

- Industrial/Commercial standards
 - Mutual agreement among companies
 - May become de facto standards
- Voluntary standards
 - By volunteers in open committees
 - Based on consensus
 - Market driven
 - Need to stay ahead of technology

18-899/Spring 1998/Chen

Global Standards Arena

- International
 - **ITU**: International Telecommunication Union
 - ITU-T: ITU Telecommunication Standardization Sector (CCITT)
 - ITU-R: ITU Radio Communication Sector (CCIR)
 - **ISO**: International Standards Organization
 - **IEC**: International Electrotechnical Commission
 - **JTC1**: Joint Technical Committee on Information Technology
- Regional
 - **CEN/CENELEC**: Committee for European Normalization
 - **PASC**: Pacific Area Standards Congress
- National
 - **ANSI**: American National Standards Institute

18-899/Spring 1998/Chen

Principles of Coding Standards

- Specify only the decoder
- Standardize the minimum

18-899/Spring 1998/Chen

“ISO/IEC JTC1 SC29 WG11”?

- Subcommittee (SC) 29
 - Working Group (WG) 1
 - Joint Bi-Level Image Group (JBIG)
 - Still pictures (1-bit to 4-5 bits)
 - Joint Photographic Expert Group (JPEG)
 - Still pictures (8-bit to 24-bit)
 - WG 11: Moving Picture Experts Group (MPEG)
 - Full-motion video and associated audio
 - WG 12: Multimedia-Hypermedia Experts Group (MHEG)
 - Data a related to multimedia and hypermedia applications

18-899/Spring 1998/Chen

Video Coding Standards

Standards Organization	Video Coding Standard	Typical Range of Bit Rates	Typical Applications
ITU-T	H.261	p×64 kbits/s, p=1...30	ISDN Video Phone
ISO	IS 11172-2 MPEG-1 Video	1.2 Mbits/s	CD-ROM
ISO	IS 13818-2 MPEG-2 Video	4-80 Mbits/s	SDTV, HDTV
ITU-T	H.262		
ITU-T	H.263	64 kbits/s or below	PSTN Video Phone
ISO	CD 14496-2 MPEG-4 Video	24-1024 kbits/s	
ITU-T	H.263 Version 2	< 64 kbits/s	PSTN Video Phone
ITU-T	H.263L	< 64 kbits/s	-

18-899/Spring 1998/Chen

Time Line and Bit Rate for Coding Standards

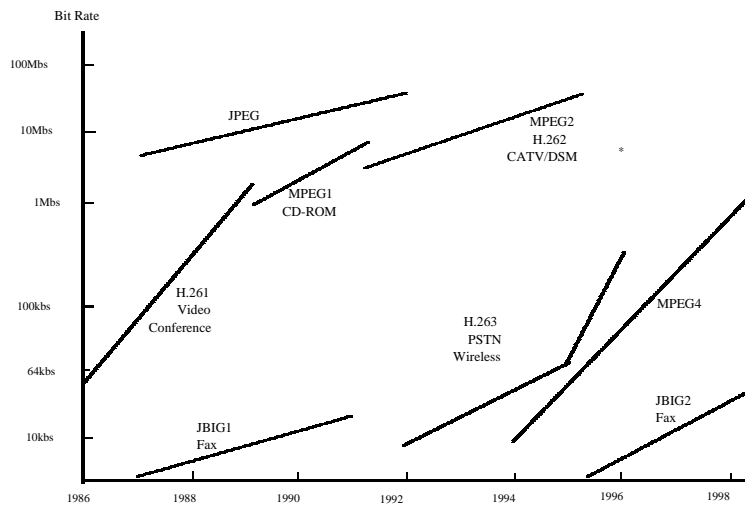

18-899/Spring 1998/Chen

Levels of Modeling

MODELS	CODED INFORMATION	EXAMPLES
Pixels	Color of pixels	PCM
Statistically dependent pixels	Prediction error or transform coeffs	Predictive Coding Transform Coding
Moving blocks	Motion vectors and prediction error	Block-based coding H.261/263, MPEG-1/2
Moving regions	Shapes, motion, and colors of regions	Region-based coding H.263+, MPEG-4
Moving objects	Shapes, motion, and colors of objects	Model-based coding MPEG-4
Facial models	Action units	MPEG-4
A/V objects	Descriptive languages	MPEG-7

18-899/Spring 1998/Chen

•
•

Levels of Modeling (cont.)

- Better modeling implies
 - Higher compression
 - More content accessibility
 - More complexity
 - Less error resilience
- Currently
 - Block-based: H.261, H.263
 - 2D region-based: H.263+, MPEG-4 Video
 - Model-based: MPEG-4 SNHC
 - High-level descriptive language: MPEG-7