

# 2

## Elevators

18-649 Distributed Embedded Systems

Philip Koopman

September 2, 2015

© Copyright 2010-2015, Philip Koopman

Picture source: [Strakosch98] Vertical Transportation Handbook

**Carnegie  
Mellon**

### Where Are We Now?

---

◆ **Where we've been:**

- Real-time Embedded Control Systems

◆ **Where we're going today:**

- You generally need to know something about the system you want to design beyond just the written specifications(!) = "domain knowledge"
- Elevators: a distributed real-time embedded control system example
  - Gathering "domain knowledge" for course project
  - Example of factors other than digital electronics that embedded system designers need to understand to do their job

◆ **Where we're going next:**

- Requirements; More on design process
- An embedded view of distributed systems

## Project Note:

- ◆ **This project is more open-ended than it might appear**
  - Some details are unspecified
  - Some behaviors are more subtle than you will see at first, and you will have to revise your understanding as you work through things
  - Many problems have multiple, equally valid solutions
  - Some solutions are probably better than others, but a “satisficing” solution is all that is required in many cases
  - Scenarios have a lot of flexibility – make any reasonable assumptions
- ◆ **In most cases, the answer to “is this the right way to do it?” is some combination of the answers to:**
  - Will it work?
  - Is it reasonable? Did we explicitly forbid it?
  - Is it exploiting a bug in the simulator or otherwise unreasonable?
  - For the first weeks, if you’re not sure about *elevator technical details* take a guess (confirm with real elevator). Ask for help with process questions at office hours.
  - **Any reasonable technical solution that we don’t forbid is OK to do. There is no single “right” answer! There are no “trick” penalties.**

## Preview

- ◆ **Status check**
  - Everyone should be tracking assignments on course schedule grid at:  
**<http://www.ece.cmu.edu/~ece649>**
  - **Blackboard has announcements and grades**
  - **TA office hours will be announced on blackboard**
  - **Initial the attendance sheet during every class!**
    - Attendance sheet circulation times may vary
  - **Project groups will form as soon as next pass on enrollment is settled**
- ◆ **Elevators are a lot more complicated than people generally think**
  - Multiple computers per elevator car
  - Multiple cars coordinated within a building
  - Very difficult optimization problems for delivering passengers efficiently
- ◆ **Many different design considerations**
  - Combining mechanical & electronic technology
  - Performance optimization
  - Human interface
  - Safety
  - Unconventional installations

## Project Example: Elevator

- ◆ **Motor control**
  - Firm real time
  - Safety critical
  - Mechanical interlocks
  - Fail safe
- ◆ **Door control**
  - Soft real time
  - Somewhat safety critical
  - Mechanical interlocks
  - Fail safe
- ◆ **Many other subsystems**
- ◆ **Most electronics for I/O and power (replaces relays)**

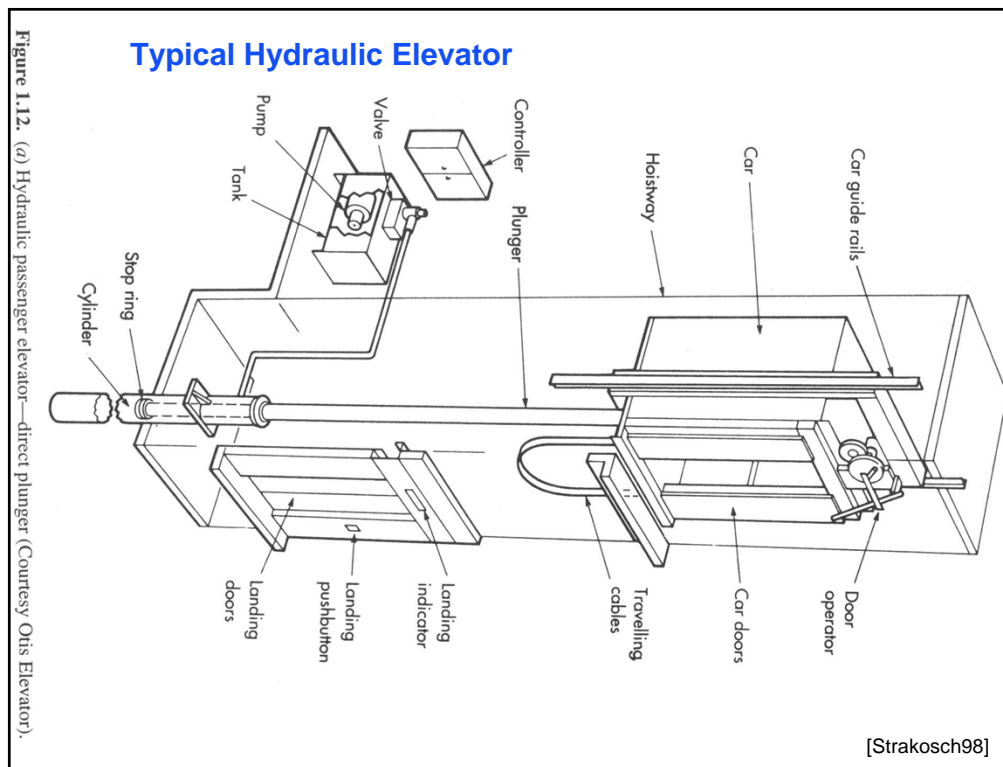

## High Performance Elevators

### ◆ Electric motors

- Cables instead of hydraulics
- AC or DC
- Fixed or variable speeds

### ◆ Typical price-performance list:

- 1-speed
- 2-speed
- Variable speed medium duty
- Variable speed heavy duty



The 51-story Woolworth Building still has the Otis gearless traction machinery installed in 1912.

[Strakosch98]

## Basic Elevator

### ◆ Counterweight at ~40% full load weight

- Smaller motor required than without counterweight
- Less power consumed

### ◆ Bottom cables help balance load

- 1000 feet of cable is a lot of weight!

### ◆ Late breaking news – Otis is switching from cables to belts of linked steel plates

- More or less a chain drive
- More flexibility means smaller motor required

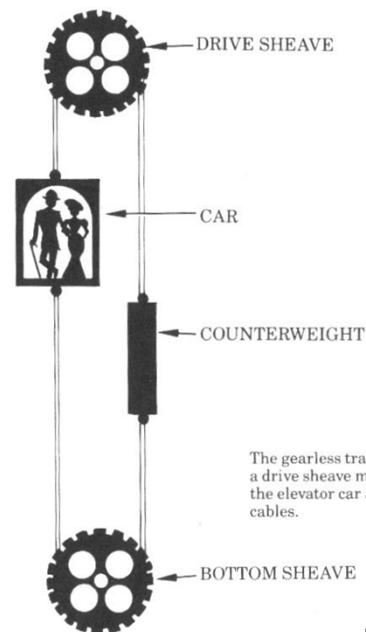

The gearless traction design has a drive sheave mounted above the elevator car and a number of cables.

[Strakosch98]

## Medium- Speed Geared Elevator

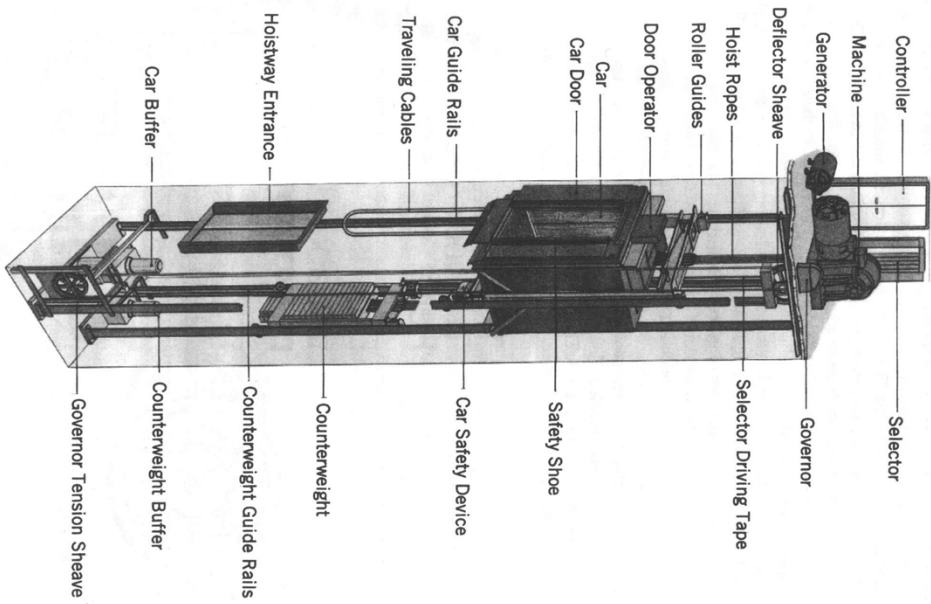

[Strakosch98]

Figure 1.5. (Continued)

(b)

## High Speed DC Gearless Elevator

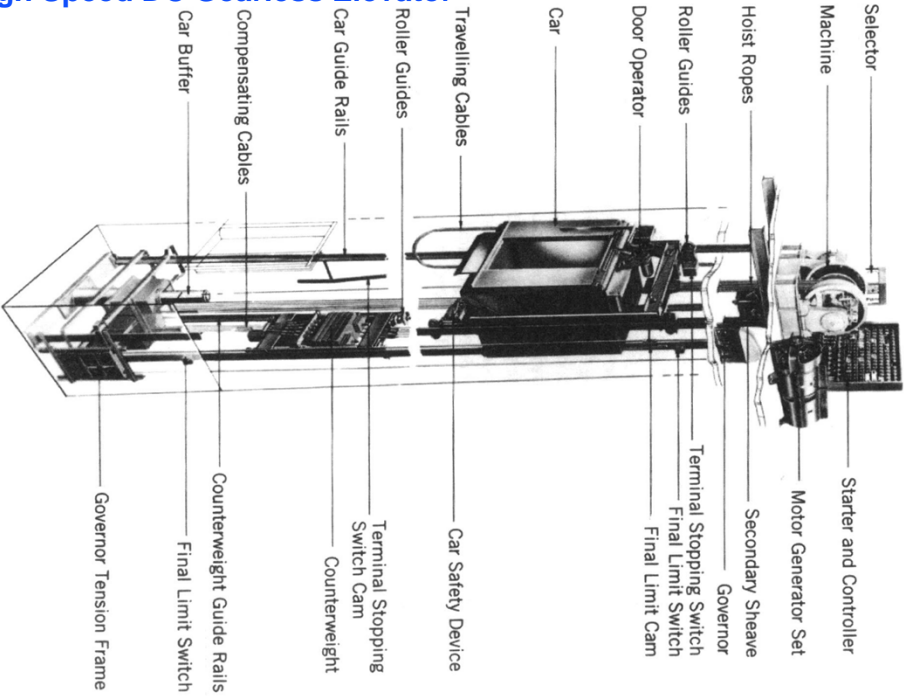

[Strakosch98]

Figure 1.5. (a) Gearless elevator installation (Courtesy Otis Elevator). (b) Geared elevator installation (Courtesy Otis Elevator).

(a)

## Getting from Here to There

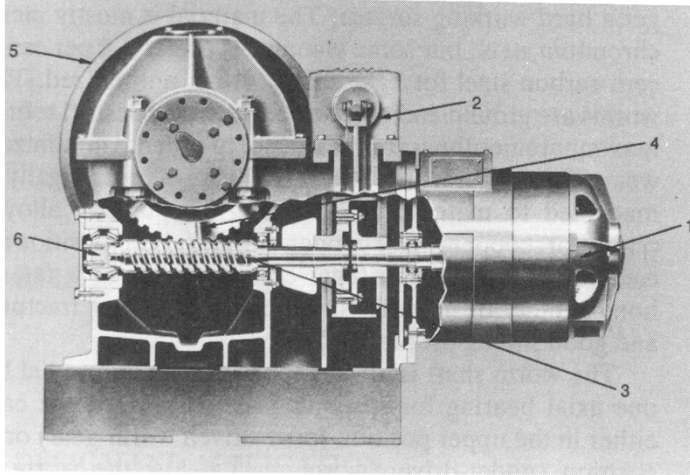

Fig. 4.1 — A typical under-driven worm-gear (Otis Elevator Co.).

1. a.c. driving motor
2. d.c. brake
3. Worm and worm shaft machined in one piece
4. Worm wheel
5. Traction sheave
6. Tapered roller bearings

[Strakosch98]

## Acceleration/Deceleration

### ◆ Acceleration profile:

- Constant jerk
- Constant acceleration
- Constant velocity

### ◆ Deceleration is the reverse, but with **leveling period**

- Leveling is slow movement to get last fractions of an inch movement
- 0.5 sec leveling period is only representative

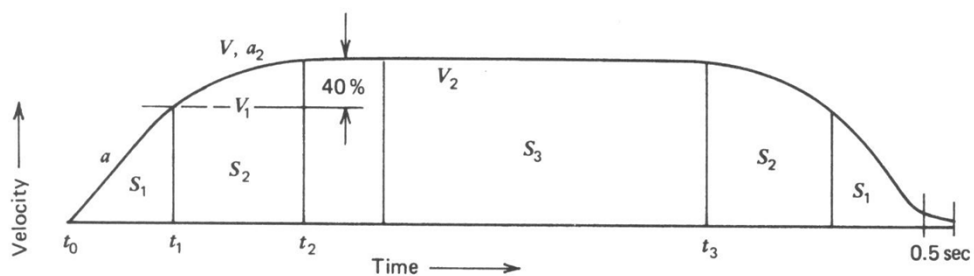

Figure 7.3. Elevator travel—velocity versus time.

[Strakosch98]

## Peak Speed Varies By Distance

### ◆ Need to keep acceleration limited for fragile passengers

- Extra-straight & smooth rails to minimize bumping at high speed
- Also, limited by air pressure change on very large buildings
- Motor size is a minor consideration – buying a bigger motor is easy

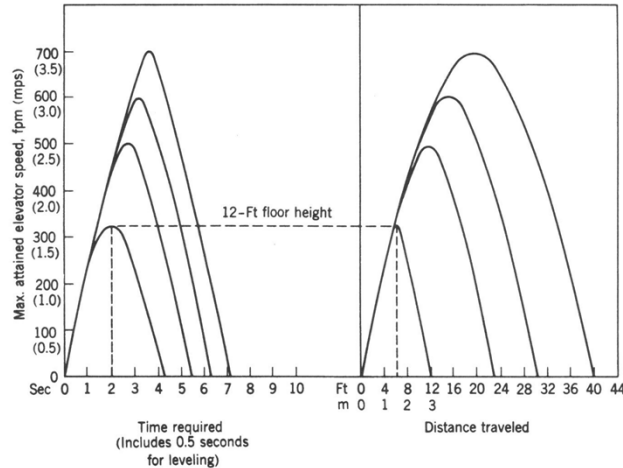

Figure 7.4. Elevator speed versus time and distance.

[Strakosch98]

## Leveling

### ◆ “Leveling” is when elevators correct a small alignment mismatch

- Elevator slightly below floor ... need to go back up
- Elevator slightly above floor ... need to go back down

### ◆ Leveling is required due to following:

- Cable slip on drive sheave when slowing down causing overshoot of floor
- Passengers enter elevator, causing cable to stretch
  - Elevator sags every time someone enters
- Passengers exit elevator, causing cable to shrink
  - Elevator springs upward every time someone leaves
- If you have 1000' of cable, it doesn't take much weight to cause noticeable stretching!

### ◆ Course project elevator requires leveling

- Passengers won't enter if elevator isn't level
- This means you might have to move even while loading passengers
  - Safety shutdown applies if you move out of the leveling zone with doors open
- (Also note: project elevator has front doors and back doors)

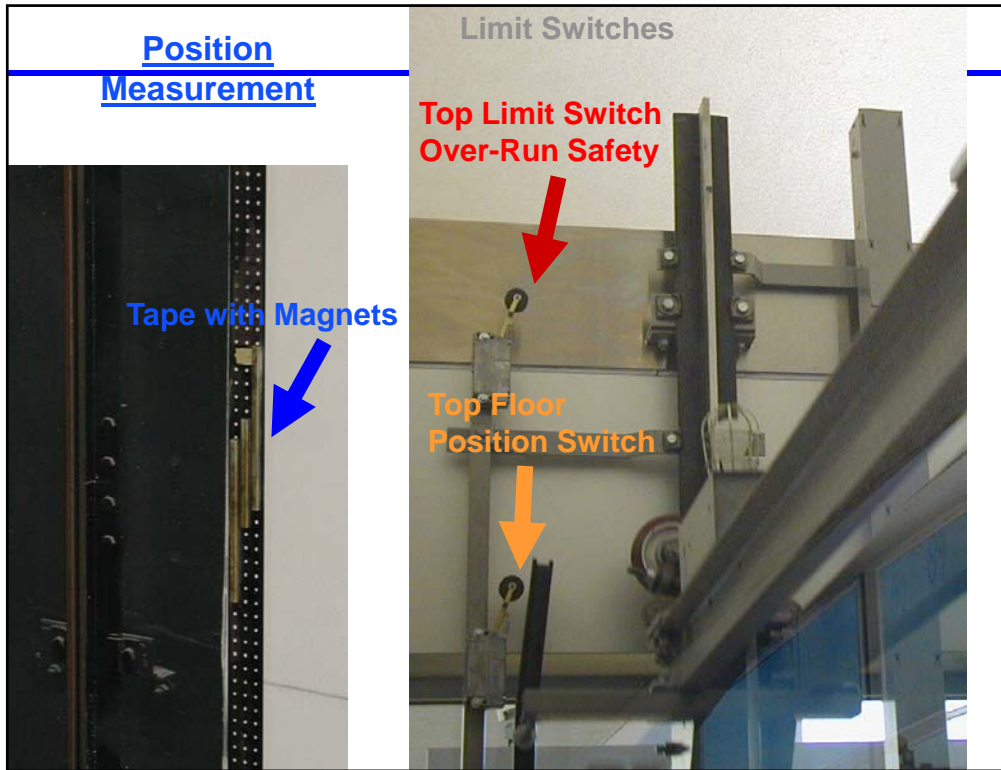

## A Smooth Ride

- ◆ **Roller guides follow T-shaped railing**
  - Bumps in guides give rough ride, even with shock absorbers

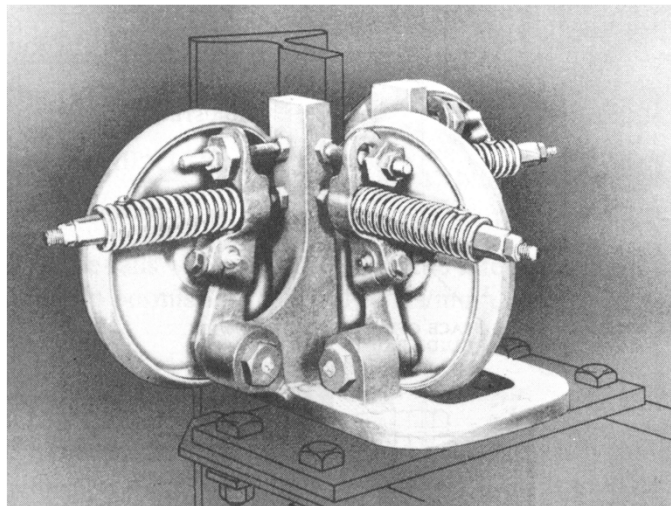
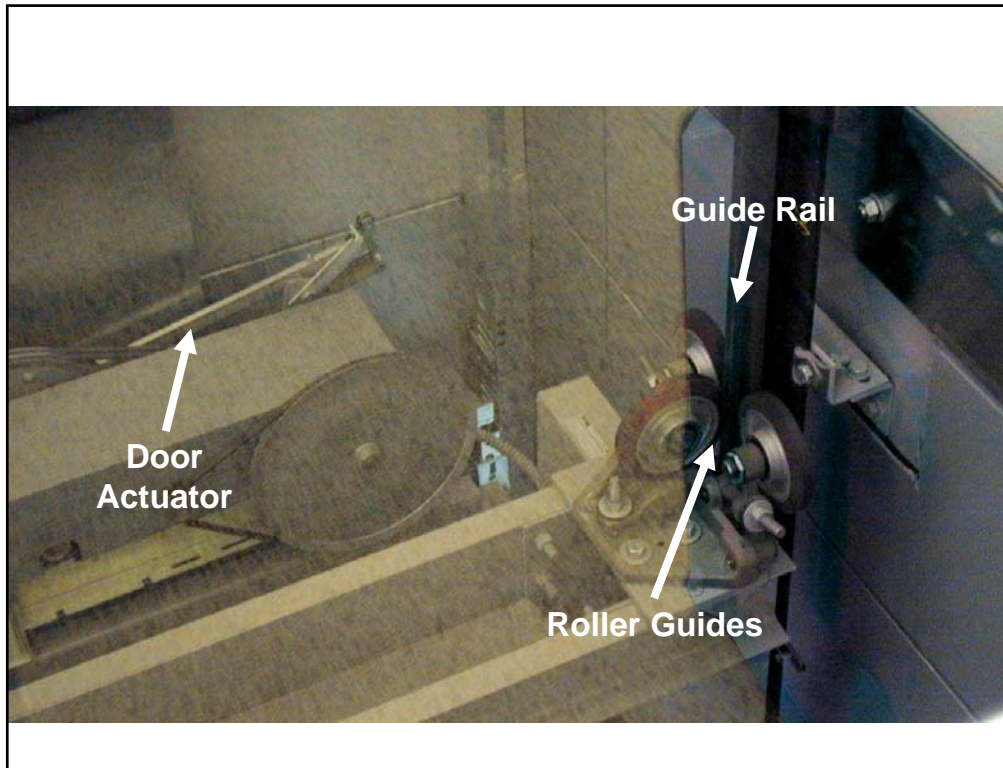

Fig. 7.8 — Roller guide shoes (Otis Elevator Co.).

[Strakosch98]





## Control Electronics

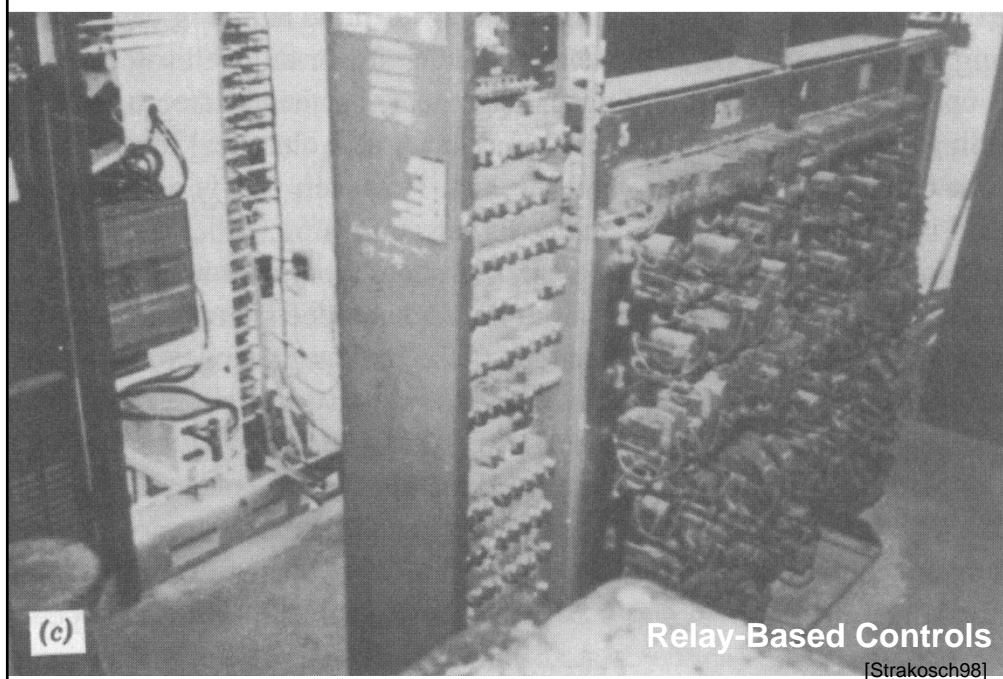

## Hierarchical Control Architecture

- ◆ Typically up to 8 cars per group; 8 groups per building

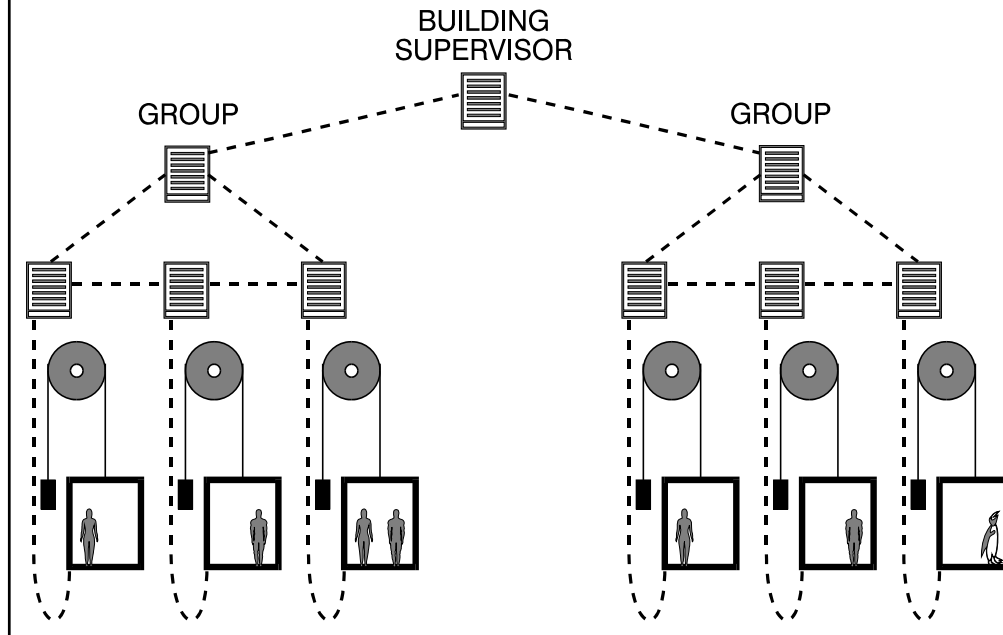

## Old Days: Relay Control

- ◆ Remember that relay computers used to exist
  - Big relays used to control power
  - Little relays used to implement switching logic
  - Many elevators are hybrid computer + relay



[http://www.wadeinstruments.com/relays/control\\_relay\\_tutorial.htm](http://www.wadeinstruments.com/relays/control_relay_tutorial.htm)



A modern controller high atop Detroit's Plaza Hotel. [Strakosch98]

## “Selector” Was A Scale Elevator Model That Tripped Relays

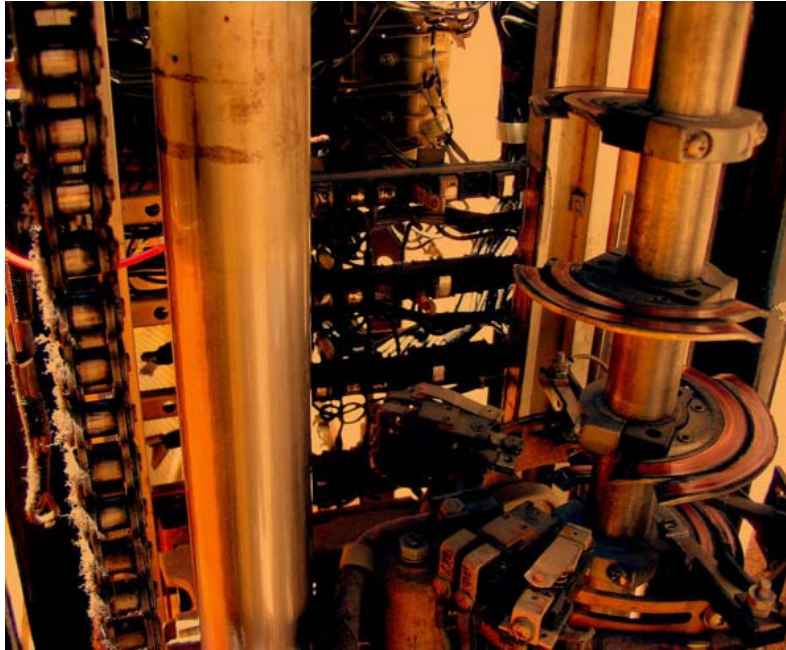

[http://www.elevatorbobs-elevator-pics.com/elec\\_sel.html](http://www.elevatorbobs-elevator-pics.com/elec_sel.html)

## Modern: Electronic Control

- ◆ **High-end CPUs for control algorithms**
  - e.g., Pentium-class CPU
- ◆ **Most of area is for power switching**
  - Still some relays
  - Power electronics

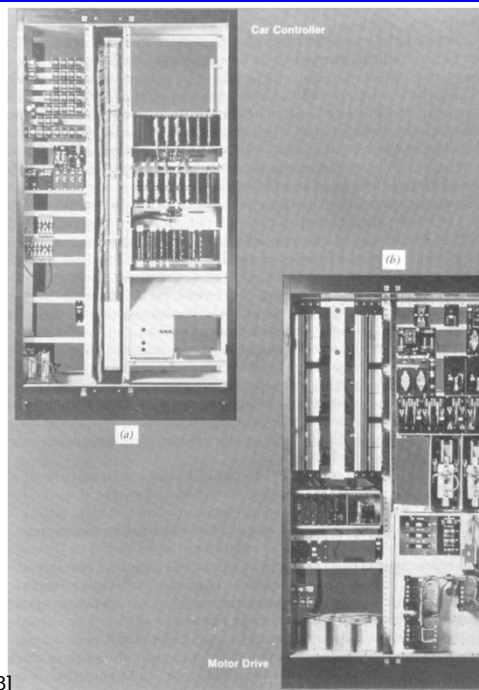

[Strakosch98]

## Embedded Distributed Architecture

◆ **Separate Control Systems for many functions**

- (Real elevators have more than are shown here.)

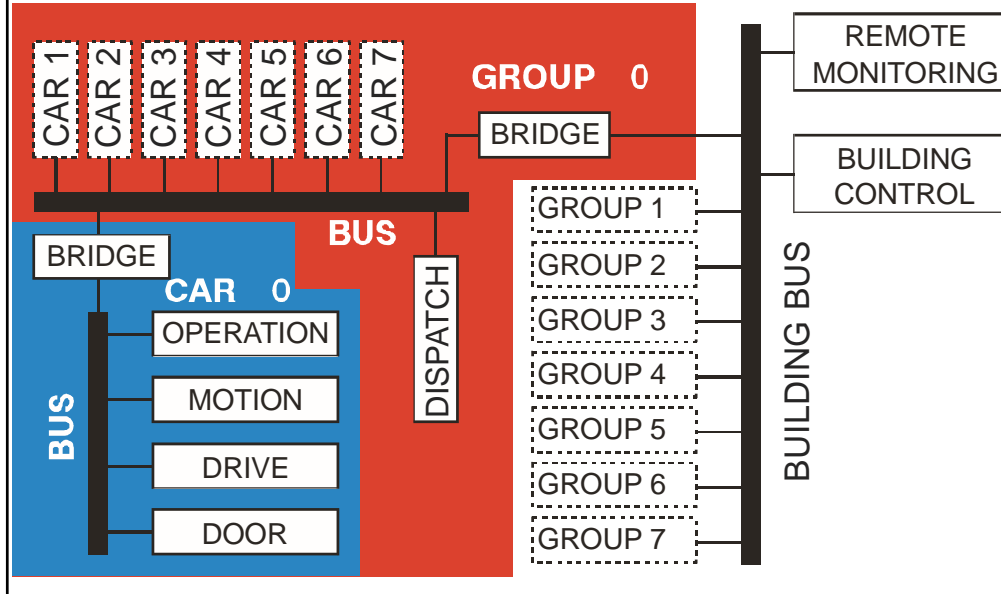

## The Otis Safety Brake

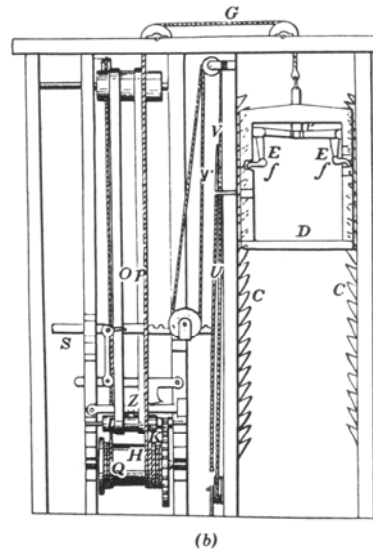

Figure 1.2. (a) Otis's demonstration, Crystal Palace, New York, 1853. (b) Otis's patent sketch for a safety device (Courtesy Otis Elevator). [Strakosch98]

# Emergency Braking

- ◆ Speed governor trips safety gear
  - Note that falling “up” is more likely than falling down

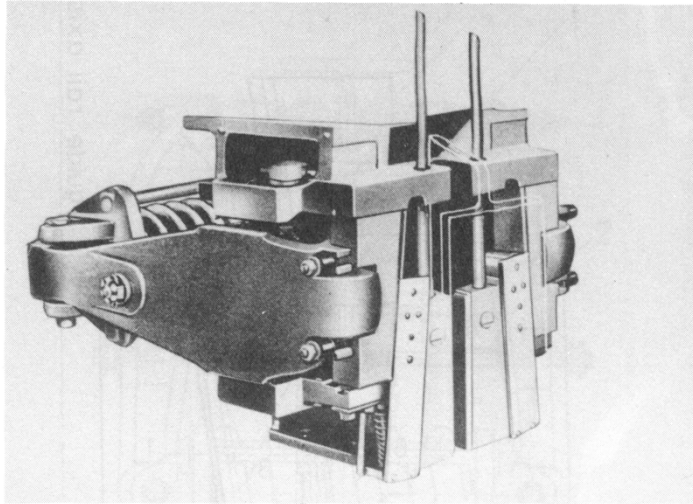
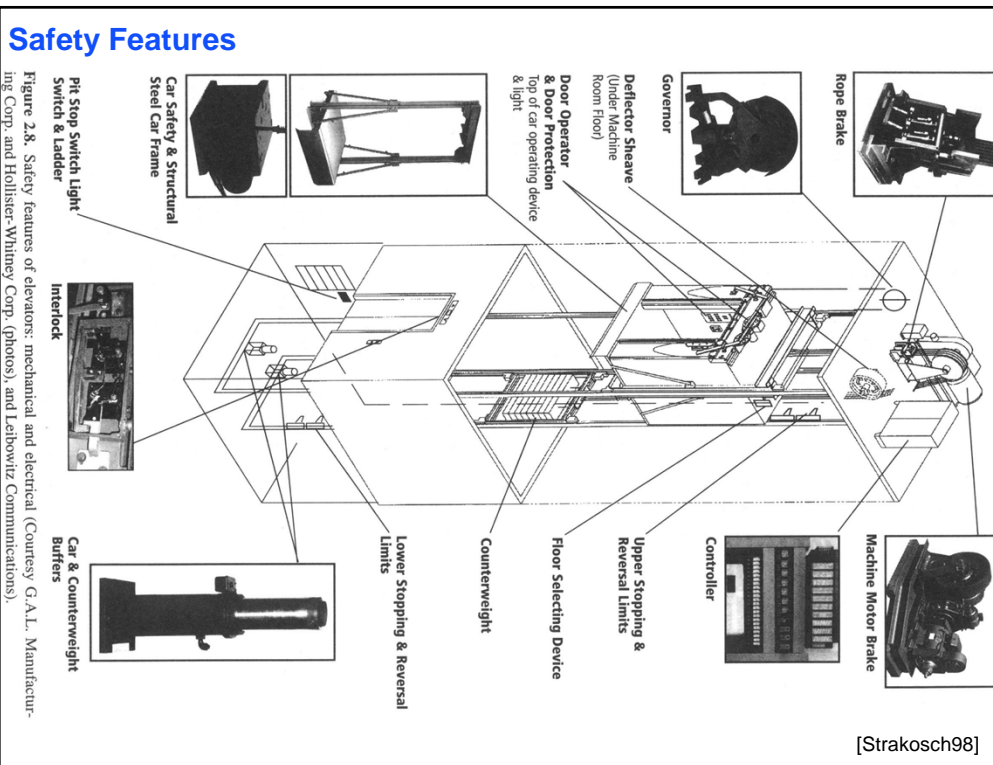

Fig. 8.7 — Flexible guide clamp safety gear for heavy duty elevators (Otis Elevator Co.) [Strakosch98]





## Human Interface



## Modern Elevators Are Robots

- ◆ Operator inputs are guidance to the robot, not necessarily commands



Fig. 12.1. Elevators being modernized while one car (center) continues in operation. [Strakosch98]

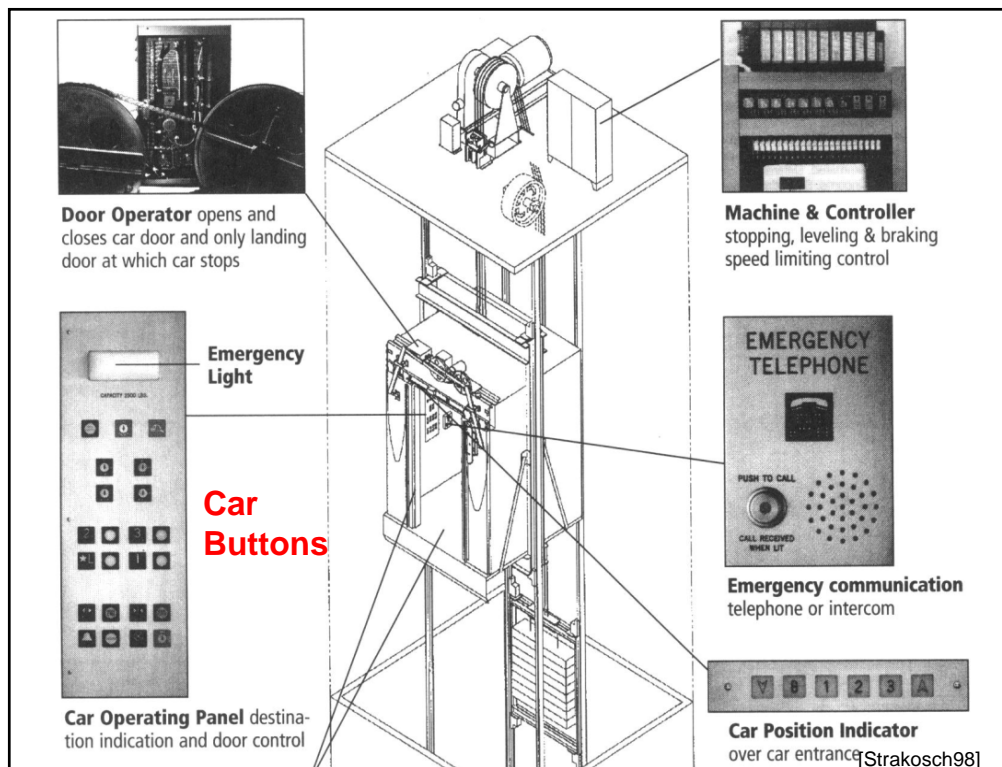

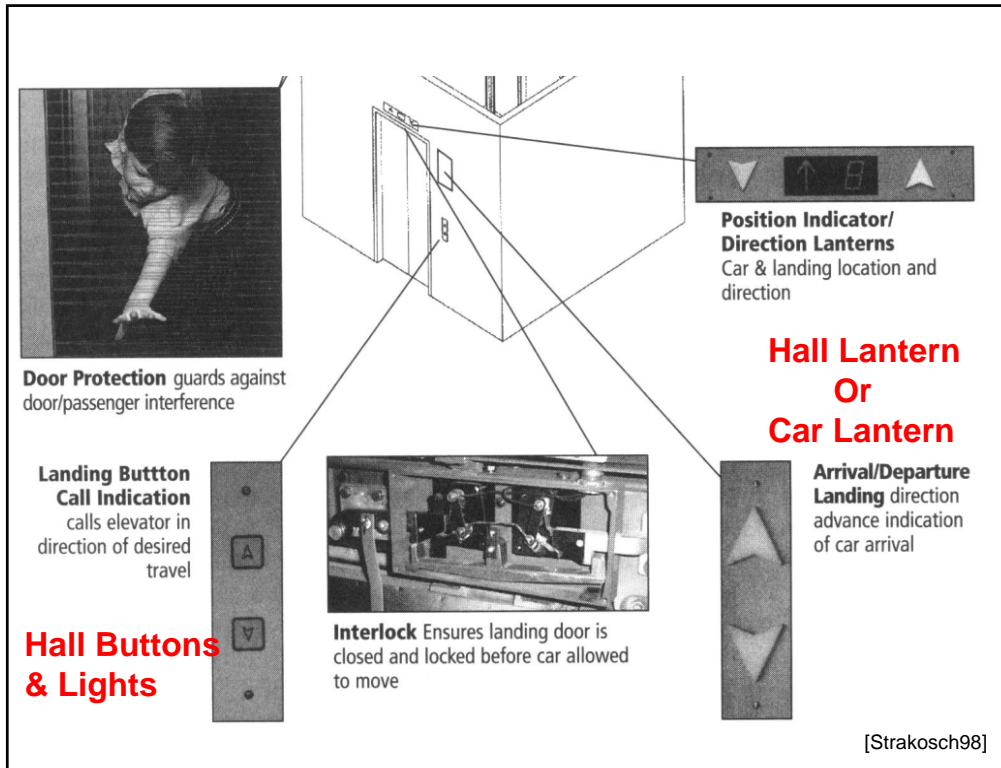

## Manual Doors

- ◆ Culzean Castle, Scotland





## Excerpt from “50 Fun Things to Do in an Elevator”

- ◆ When arriving at your floor, grunt and strain to yank the doors open, then act embarrassed when they open by themselves.
- ◆ Greet everyone getting on the elevator with a warm handshake and ask them to call you, "Admiral".
- ◆ Meow occasionally.
- ◆ Say, "Ding!" at each floor.
- ◆ Stare, grinning, at another passenger for a while, and then announce, "I've got new socks on!"
- ◆ Bring a chair along.
- ◆ [bonus] Say: "I've done a design review of the software in this elevator" and then hold onto the side railings for dear life.

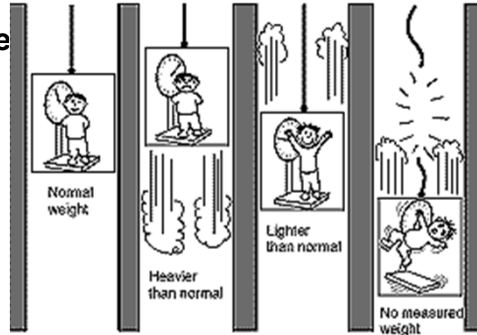

<http://quest.nasa.gov/space/teachers/liftoff/micro.html>

**Disclaimer:** The 18649 course staff do not advocate or recommend any of these practices. Jumping in an elevator can trigger the safety brake.

## Elevators “Controlling” People

- ◆ **Elevators make people move via lights & other behaviors**
  - People get in when correct hall lantern direction is illuminated
    - Special case: neither lantern illuminated means everyone gets in
  - People get out when correct floor shown on car floor indicator
  - People press buttons until they see button light illuminate as confirmation
- ◆ **Special door & alarm behavior**
  - Alarm sounds when car is over-weight
    - If doors open, people will get out when they hear the alarm
  - Door “nudge” is there to shove people out of the way
    - Slow speed door operation with low torque
    - Door reversal is inactive during nudge – it nudges people out of the way

## Elevating

- ◆ Performance analysis and optimization
- ◆ How many hoistways per building?
  - Elevator hoistways are *expensive* (area multiplies for every story)
  - Limit to building size is elevator capacity

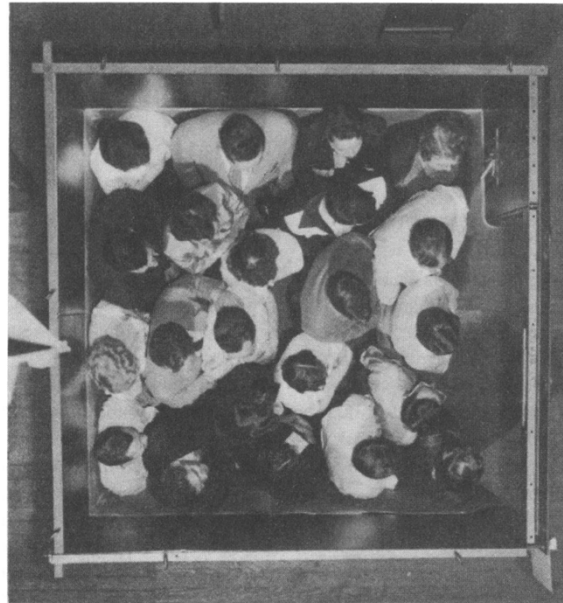
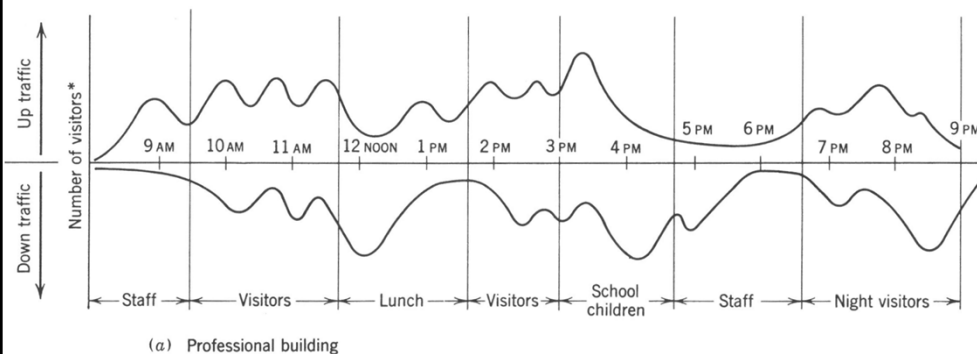

Figure 6.1. Heavy elevator car loading. [Strakosch98]

## Daily Usage Profiles

- ◆ “Up-peak” during morning rush hour
  - Send cars to lobby
- ◆ “Down-Peak” in evening
  - Optimize for people heading to lobby
- ◆ Profiles differ by building type, hour, day-of-week, and building design
  - Some buildings even have lobbies on the 5th floor...



[Strakosch98]

## Key Concepts For Dispatching

- ◆ **Dispatching: assigning a particular car to stop at a particular floor**
  - Group dispatching (multiple cars) is really difficult to do well
  - We're doing one car to make it easier
- ◆ **Key concept: Desired Floor**
  - The floor the dispatcher wants to stop at next (usually due to button press)
  - Might be different than current floor elevator is on
  - Can vary with time as new button presses arrive
- ◆ **Key concept: Commit Point**
  - Point after which it becomes too late to stop at a floor
  - Might be multiple floors away due to acceleration profile
  - Varies depending on current elevator speed
- ◆ **Key concept: Desired Direction**
  - Direction elevator will travel *after* the next stop
  - Will be different than direction of motion at end of a run
    - Example: Elevator is currently at floor 5 (current floor) moving up (current direction); dispatcher wants to stop at floor 7 (desired floor) and after that go down (desired direction); dispatcher decelerates starting 6 m before floor 7 (commit point); stops at floor 7; doors open and the Down Hall Lantern is illuminated when doors open on floor 7.

## Commit Point Calculation

- ◆ **Stopping distance:**  
**The distance between where you are now and where you can stop**
  - Assumes following normal (non-emergency) acceleration profile
  - At high speeds, this might be multiple floors away
- ◆ **Commit Point:**  
**The elevator position at which you must decide whether to stop at particular floor**
  - Occurs when elevator reaches the stopping distance from that floor location
  - This is a function of elevator speed!
- ◆ **When you pass the commit point, you lose the option of stopping**
  - Even if you still haven't reached the floor yet
  - Think of the "point of no return" for that floor

## Elevator Motion Profiles

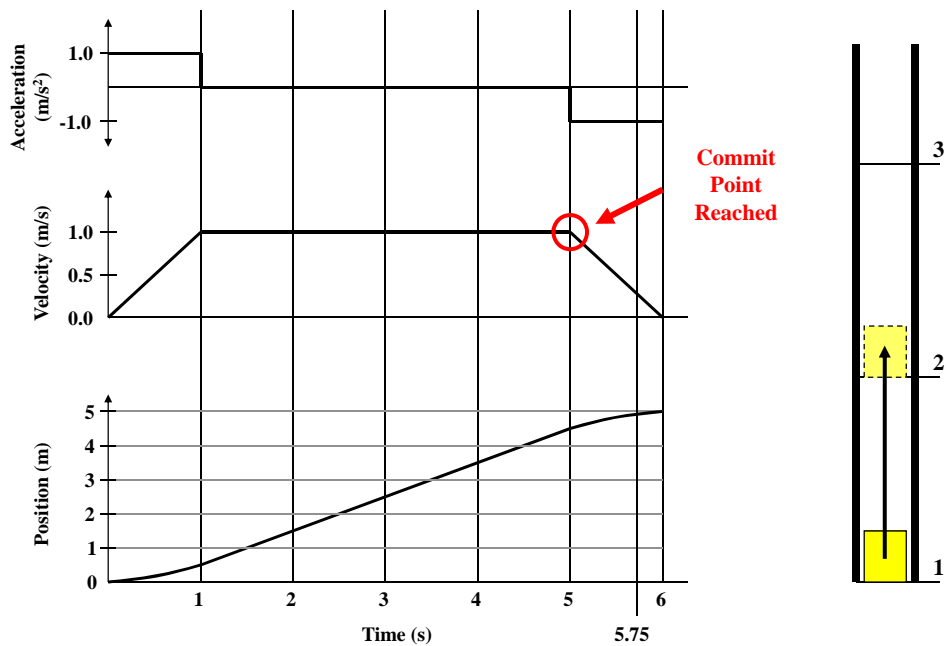

## Using The Commit Point

- ◆ **The commit point gets further away as speed increases**
  - When stopped, the commit point is exactly at the floor (stopping distance = 0)
  - At high speeds, commit point is several floors away from elevator position
- ◆ **The course project elevator can stop “instantly” from slow speed**
  - But, from fast speed you need to ramp down
- ◆ **Computation must be conservative, take into account**
  - Granularity of sensor inputs
  - Worst case network delays
- ◆ **Controllers need to have a consistent notion of commit point**
  - Not too difficult in the fault-free case, or with dropped message faults
- ◆ **In real elevators, how does commit point usually affect car floor indicator?**
  - Why?

## A Few Elevator Operating Modes

- ◆ **Parking / shutdown**
- ◆ **Maintenance / inspection modes**
- ◆ **Independent service**
  - Someone can control elevator with controls in the car
  - Ignore hall calls
  - Useful for movers, operators in fancy hotels or stores
- ◆ **Building security**
  - Restrict access to some floors
  - Card key or key code access only
  - Homing to lobby for visual inspection of the car
- ◆ **Maternity ward mode**
  - Babies are tagged with RFID bracelets
  - Elevator automatically returns to maternity ward if bracelet is detected
- ◆ **Sabbath / Streetcar mode**
  - Sabbath observance prohibits doing work, including pressing buttons
  - Behavior similar to the baseline dispatcher from course project



[Photo credit: [http://commons.wikimedia.org/wiki/File:Sabbath\\_on-off.jpg](http://commons.wikimedia.org/wiki/File:Sabbath_on-off.jpg)]

## A Few Emergency Operating Modes

- ◆ **Generally initiated by key switches, sensors, or special panels**
- ◆ **Fire Modes – two stages**
  - Stage 1 – return to lobby and clear the elevators
  - Stage 2 – rescue workers control the car
  - Different state and municipal elevator codes require different behaviors for car buttons
- ◆ **Hospital operations – “Code blue”**
  - Stage 1 – Override current calls and bring the elevator to a certain floor
  - Stage 2 – Independent service (controlled from car by hospital staff)
- ◆ **Earthquake mode**
  - Move the car in a direction that avoids passing counterweight
- ◆ **Riot mode**
  - Exclude the lobby or lower floors to prohibit access to the rest of the building



Fire Stage 1



Fire Stage 2



<https://secure.flickr.com/photos/doctorow/845112794/sizes/m/photost/>

## Elevators & the Course Project

### ◆ Discrete event simulation of multi-CPU elevator

- Fine grain distributed system – every button, light, motor has its own CPU on an embedded real time control network
- No actual hardware – we provide simulation infrastructure in Java

### ◆ Emphasis on complete flow of design process

- Requirements => Design => Implementation => Test
- Simple elevator first half of course
- Redesign for more complex elevator second half of course
- High quality design process is more important than amazing elevator algorithms
  - (But, there is a small bonus for best performing elevator)

To: koopman@cmu.edu

Subject: Re: Request for Professional Reference

From: <student@andrew.cmu.edu>

Date: Mon, 26 Mar 2012 17:43:36 -0400

Hi Dr. Koopman,

Thank you for your support with the process. I will most probably be accepting the offer from Qualcomm. The position is of embedded Linux kernel development. **I also wanted to mention that during the course of my interviews I spoke to a lot of people about the elevator project and a lot of the employers were quite impressed with the process that the project tries to teach.** Some of the questions I was asked in addition to the process were things like, Why use a time triggered design as opposed to event triggered? Why use Java instead of C or C++? How did you ensure robustness of each of the controllers in the presence of stale messages? What would happen if one of the controllers went down? Overall the project was very valuable in terms of my interviews. I wanted to thank you for that as well.

Regards,  
<student>

## Unconventional Elevators

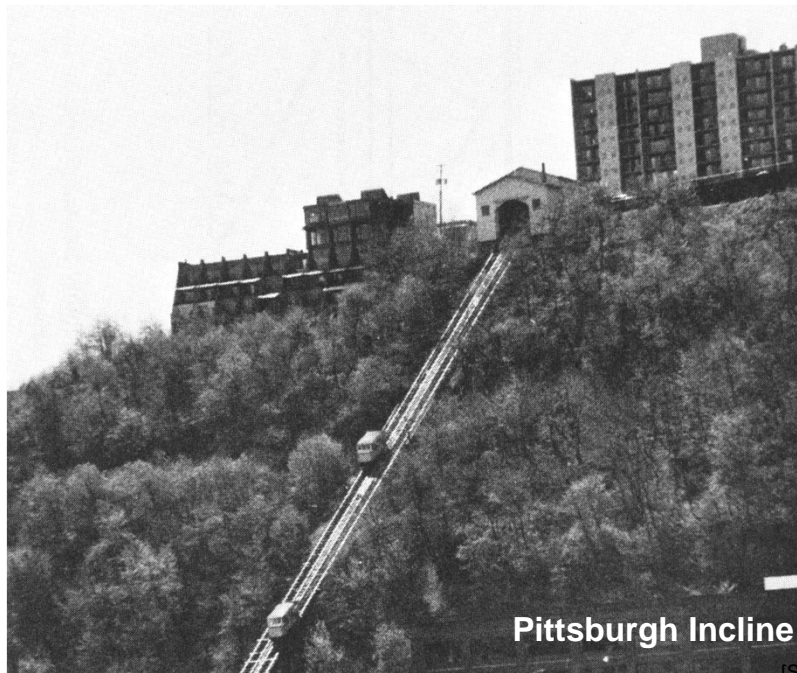

[Strakosch98]

## How Do You Maximize Capacity?

- ◆ Old idea: conveyor belt approach / paternoster
- ◆ New idea: “free cars” that attach and detach from central cable

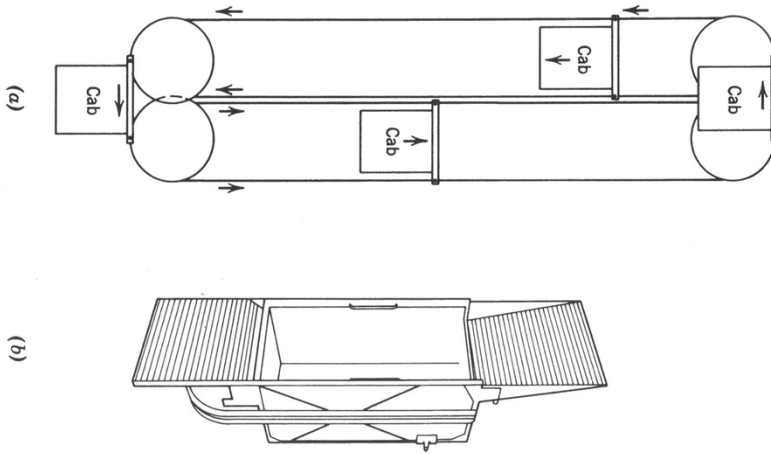

Figure 5.1. (Continued) (c) Actual installation.

[Strakosch98]

## Paternoster Elevator

Figure 5.1. "Paternoster elevator" (Courtesy *Elevator World Magazine*). (a) Schematic; (b) paternoster car.



[Strakosch98]

## Elevator Videos

### ◆ Paternoster, a Cyclic Elevator:

- <http://www.youtube.com/watch?v=OXSnNzGJDdg>

#### ◆ Paternoster, a Cyclic Elevator

ino90 12 videos  Subscribe



### ◆ Paternoster: Eastern Europe's Elevator of Death

- [http://www.youtube.com/watch?v=Ro3Fc\\_yG3p0](http://www.youtube.com/watch?v=Ro3Fc_yG3p0)



## Review

---

- ◆ **Elevators span a large price-performance range**
  - 2-story hydraulic elevators
  - 100+ story high-end systems
- ◆ **Tricky blend of technologies**
  - Mechanical/motion
  - HW/SW/mechanical safety
  - Dispatching heuristics
  - Human interface
- ◆ **Dispatching fundamentals**
  - Workload varies by time of day
  - Dispatcher thinks about where it is going next before it even stops at a floor