



An Introduction

Thank you for purchasing a JL Audio W7 subwoofer driver. The W7 embodies JL Audio's commitment to pushing the envelope of speaker technology, with eight patented technologies, a design patent and a completely unique set of component parts. Each W7 model has been meticulously engineered to reproduce sub-bass with extreme fidelity at any volume level, provided it is installed and tuned properly. Please review the information in this document carefully so as to maximize your enjoyment of the W7's capabilities.

Two enclosure recommendations are listed for each model, one sealed and one ported. The sealed enclosure design will, in most cases, give you the best overall sound quality and take up the least space in your vehicle. The ported enclosure design will deliver additional output over the sealed enclosure (about 3 - 4 dB more) and will also maintain excellent sound quality, but it will require significantly more space to install. The recommended ported enclosure is not designed for peaky "competition SPL" performance, it is designed for music listening. It will be very loud and sound extremely good when set up properly.

In addition to the enclosure recommendations, we also provide recommended amplifier settings for JL Audio amplifiers used with W7's. Some of this information is also applicable with other brands of amplifiers (like crossover points and slopes), some is not (like the voltage levels specified for input sensitivity settings). You will notice that our recommended settings do not include any bass EQ boost... this is because W7's rarely require any equalization to produce smooth frequency response. If you have an equalizer in your system (or one is included in your head unit or amplifier), defeat all bands below 125 Hz before dialing in your new system settings. Please turn off all sound processing that would affect the subwoofers (loudness circuits for example).

For optimum sub-bass performance, the amplifier input sensitivity must be adjusted to avoid excessive distortion (clipping) of the amplifier output. With W7 subwoofers, a clipped amplifier output will manifest itself audibly as a low-level "mechanical" sound coming from the speakers. Proper input sensitivity setting will avoid this problem. Overly high input sensitivity settings result in no additional clean output but will result in poor sound quality and reduced speaker reliability.

Please consult the input sensitivity setting information on page 14 of this book.

RECOMMENDED CONTINUOUS (RMS) POWER RANGE FOR ONE SUBWOOFER DRIVER:

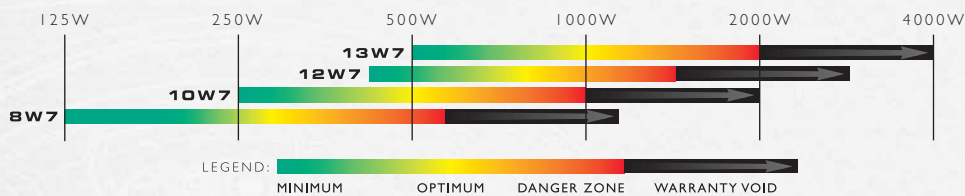

GREEN (MINIMUM):

From a reliability standpoint, this zone represents a very comfortable operating power range for each driver. This level of power will not stress the woofer but will not extract all of its performance potential, either.

Use of less than the minimum power level will not damage the woofer, but may result in unsatisfactory performance.

YELLOW (OPTIMUM):

This zone represents the best compromise between long-term reliability, high-output and low-distortion performance and is centered on each woofer's continuous power rating (as published in its specifications). In this zone, you will be taking full advantage of the woofer's optimum, low-distortion performance range without undue risk of failure.

RED (MAXIMUM):

In this zone, low-distortion output and long-term reliability will be compromised (especially by an aggressive user). Slightly more SPL will be gained by pushing the power into this zone, but typically not more than 2dB, compared to the yellow zone. The closer you are to the black zone, the higher the likelihood of driver failure. Operate with caution.

BLACK (WARRANTY VOID):

We do not recommend operating woofers at this level of power. In this zone, there is a very high probability that the driver will fail due to excessive heat and/or mechanical stress.

Subwoofer drivers operated at these levels of power are NOT covered under warranty.

When designing systems with W7 drivers, it is very important to achieve a good power match between the subwoofer amplifier and the subwoofer driver's capabilities. The power levels listed in the above chart represent continuous (RMS) amplifier power per woofer and assume that the user will regularly make full use of that power **without drastically overdriving (clipping) the amplifier(s). Make sure you factor system impedance and the total number of subwoofers into your calculations. Adhering to these power recommendations will result in systems that are both reliable and enjoyable.**

W7 Technologies

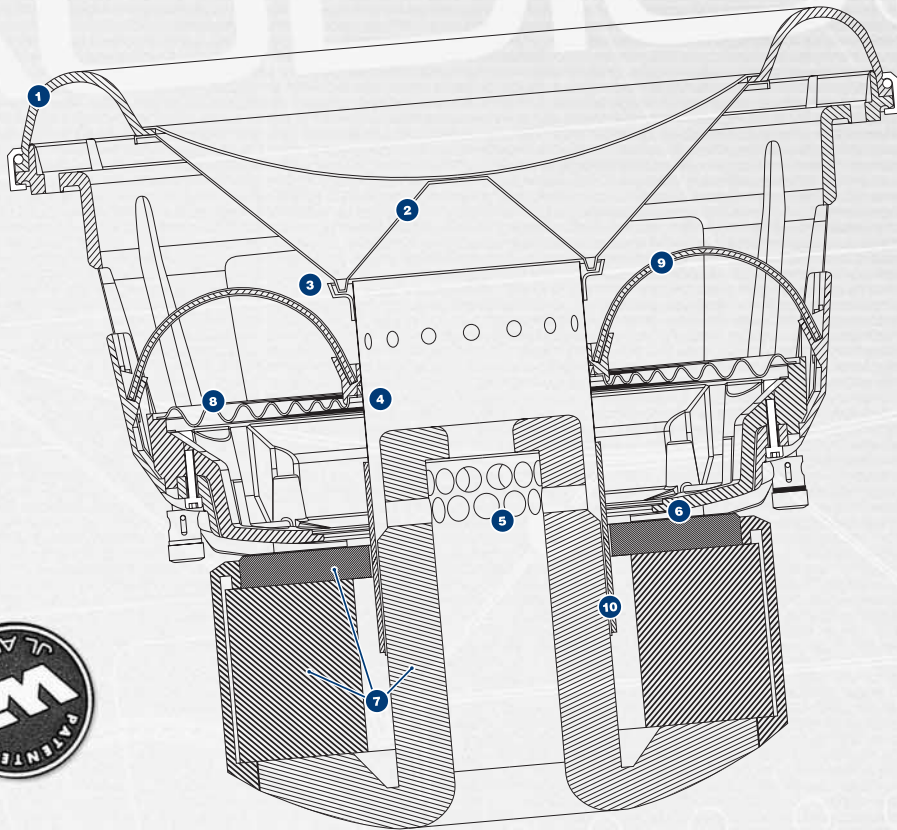

1 - OverRoll™ Surround (U.S. Patent #5,687,247 and #5,949,898)

By utilizing space wasted in conventional speakers, this ground-breaking innovation controls the W7's massive excursion without sacrificing precious cone area.

2 - W-Cone™ (U.S. Patent #6,496,590)

The W-Cone™ is a unit-body cone assembly that delivers astonishing cone stiffness with minimal mass. The shape also provides incredible torsional rigidity, which is critical to maintaining voice coil alignment at the suspension limits.

3 - Floating-Cone™ Attach Method (U.S. Patent #6,501,844)

Our newly conceived assembly technique ensures proper surround geometry in the assembled speaker for better excursion control and dynamic voice coil alignment. A small detail that means a lot when you're pumping the cone to the excursion extremes the W7 is capable of.

4 - Plateau-Reinforced Spider Attachment (U.S. Patent #6,118,884)

A derivative of JL Audio's famous VRC technology, this bulletproof suspension attachment relieves stress from the spider material at high-excursions for enhanced reliability.

5 - Radially Cross-Drilled Pole Piece (U.S. Patent #6,243,479)

This innovative venting system greatly enhances thermal dissipation and power handling by directing air flow onto the voice coil former, working in conjunction with technology #6.

6 - Massive Forced-Air-Cooled Aluminum Alloy Frame (U.S. Patent #D472,891, #6,219,431 and #6,229,902)

The elevated frame design of the W7 delivers cool air through slots directly above the top-plate to the voice coil of the speaker. This not only enhances power handling, but also sound quality by minimizing dynamic parameter shifts and power compression.

7 - Highly Linear, DMA-Optimized Motor System

DMA is JL Audio's proprietary Dynamic Motor Analysis system and is aimed at improving dynamic motor behavior. As a result of DMA optimization, W7 motors remain linear in motor force over an extreme range of excursion and also maintain a highly stable fixed magnetic field in the gap over a wide power range. This leads to vastly reduced distortion and faithfully reproduced transients... or put simply: tight, clean, articulate bass.

8 - Huge Diameter, Progressive-Roll Spider

Arrived at after intense computer analysis and optimization, the W7 spiders provide precise control and motor/voice coil alignment without prematurely limiting excursion.

9 - Co-Extruded Double Lead-Wires

The extruded casing and carefully engineered attachments ensure controlled lead-wire behavior under the most extreme excursion demands. Two conductors are used per connection for ample current carrying capability.

10 - Ultra-long Voice Coil

To allow extreme linear excursion, phenomenal power handling and control, control, control.

In addition to the patented technologies listed above, multiple U.S. and International patents are currently pending.

WARNING: Prolonged exposure to high sound pressure levels can lead to permanent hearing loss. W7 subwoofers are capable of reproducing sound at extremely high sound pressure levels. Please exercise restraint in the operation of your system in order to preserve your hearing and your long-term enjoyment of this product's sound quality capabilities.

13W7-D1.5

Free Air Resonance (Fs): 23.5 Hz
Electrical "Q" (Qes): 0.476
Mechanical "Q" (Qms): 7.517
Total Speaker "Q" (Qts): 0.448
Equivalent Compliance (Vas): 3.68 cu. ft. (104.3 ltrs)
One-Way, Linear Excursion (Xmax)*: 1.25 in. (32 mm)
Thermal Power Handling (Pt): 1000 Watts Continuous
Reference Efficiency (no): 0.269 %
Efficiency (SPL @ 1W/1m): 86.3 dB
DC Resistance (Re): 2.41Ω
Effective Piston Area (Sd): 107.35 sq. in. (0.0693 sq. m)
Nominal Impedance (Znom): Dual 1.5Ω

* Xmax specifications are derived via one-way voice coil overhang method with no correction factors applied.
 ** For parallel-wired voice coils, divide "Re" by 4. All other specifications remain the same.



RECOMMENDED CONTINUOUS (RMS) POWER RANGE FOR ONE SUBWOOFER DRIVER:

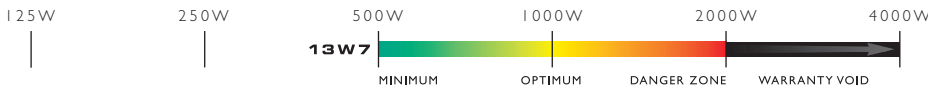

Amplifier Recommendation: 1000/1

JL AUDIO 1000/1:

These settings are intended as a "baseline" for tuning your system. Depending on your vehicle and your preferences, some variation in the crossover and bass control settings may be necessary for optimum performance.

Bass EQ:

Generally not necessary in W7 applications (we recommend defeating it by switching the "Bass EQ" switch to "Off"). May be used with Remote Bass Control to provide some user controllable broad bass boost. When used in this manner; set "Q" to "1.1", set "Center Freq." to "45" Hz, "Boost" is defeated by connection of Remote Bass Control.

Infrasonic Filter:

Turn "Off" for Sealed Enclosure.
Turn "On" for Ported Enclosure and set the knob to "25" Hz.

Input Sensitivity Controls:

Proper adjustment of these controls is critical!
For virtually all aftermarket head units, set "Input Voltage" to "Low". See "Input Sensitivity Setting Guide" on pg. 14 for precise setting instructions.

Dual Mono Speaker Output Connections:

Connect 8ga. wire directly to "+" and "-" "Subwoofer Output" connections and to the W7.

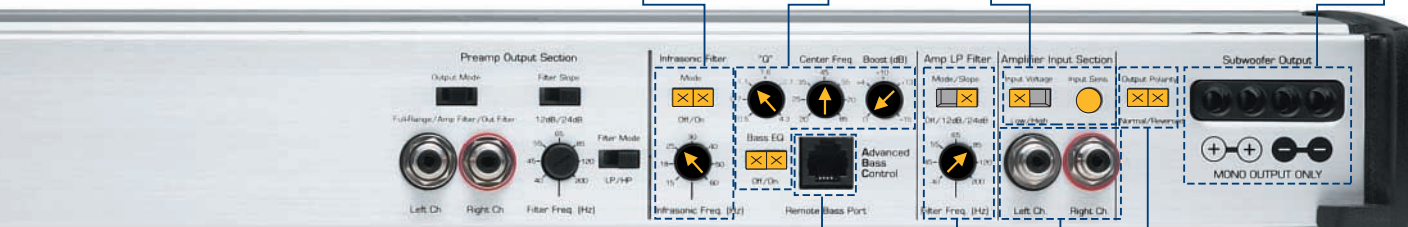

Remote Bass Port:

Permits connection of an optional remote bass boost controller (RBC-1), giving you control over the boost of the parametric EQ from the front of the car. The RBC-1 controller is sold separately.

Amp Low-Pass Filter:

Set "Mode/Slope" switch to "24dB". Set "Filter Freq. (Hz)" knob to "85". Lower settings are likely to result in a poor transition between the upper response of the W7 and the lower response of the mid-bass speakers.

Amplifier Input:

Connect RCA-type cables from the head unit (or processor) to these two jacks. Use both jacks (with a Y-adaptor if necessary).

Output Polarity:

Carefully listen to the sub-bass to mid-bass transition with music that has strong mid-bass content. Select the switch position which gives the smoothest, most natural mid-bass response. If using multiple 1000/1's on multiple subwoofers, make sure this switch is set to the same position on all amplifiers.

- = position of knob
- = position of switch
- = switch with two possible positions
- = setting will vary (see sidebar)

Driver Specifications

Grille Clearance: 2.7 in. (69 mm) from the bottom of the mounting flange to the lowest inside surface of the grille.

Displacement: 0.21 cu. ft. (5.9 ltrs)

Net Weight: 52 lbs. (23.6 kg)

Mounting Hardware: Twelve #12 x 1.75" long clear, zinc-plated steel Phillips pan-head sheet metal screws (included) **or** twelve #12-28 long steel Phillips pan-head machine screws with #12-28 T-Nuts, each at least 1/2-inch (12.5 mm) longer than the thickness of the mounting baffle (not included).

Unpacking/Mounting: Please refer to the "How to: Mount a W7 Subwoofer" on pages 4 & 5 for detailed, step-by-step instructions.

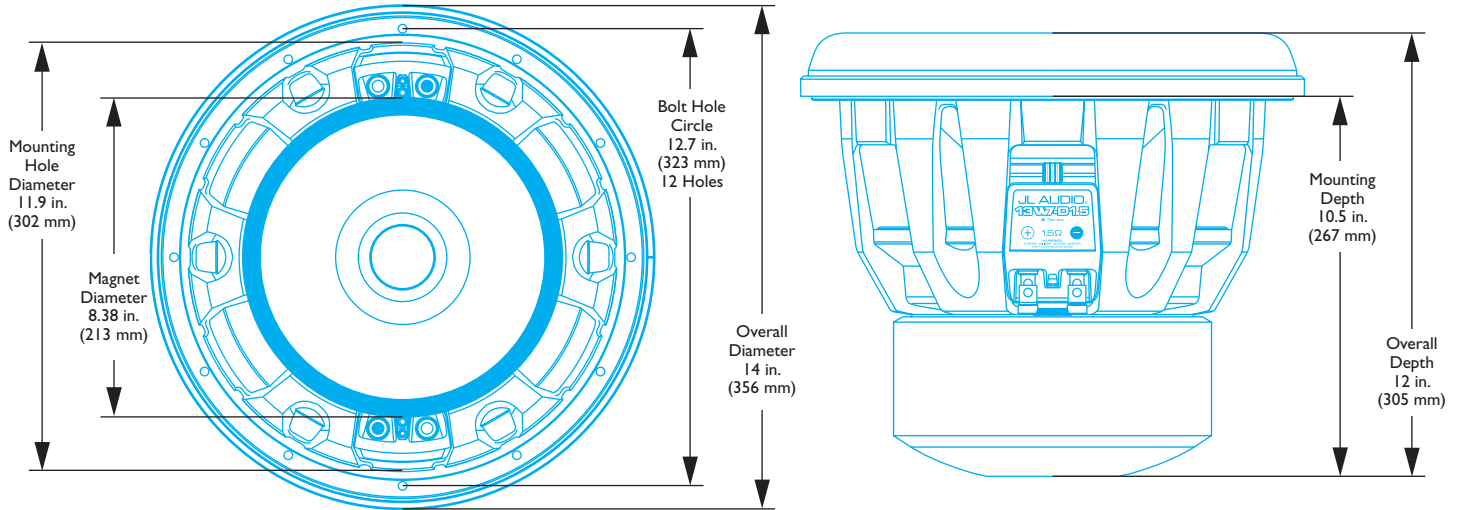

Enclosure Specifications

Net volumes given below do not include the air volume displaced by the speaker (Driver Displacement). This value must be added to the net volume along with the displacement of any braces and/or ports (if applicable) to arrive at a gross internal volume. Air inside a port is not part of the effective net volume. Calculate ports as solid, not hollow objects.

The dimensions given for the enclosure examples below take all applicable displacements into consideration.

SAFETY NOTICE!
It is absolutely essential that the completed subwoofer enclosure is mounted firmly to the vehicle with heavy steel bolts (1/2 inch diameter) and large steel washers on both sides of the bolts. This will reduce the likelihood of occupant injury in the event of a collision or sudden deceleration.

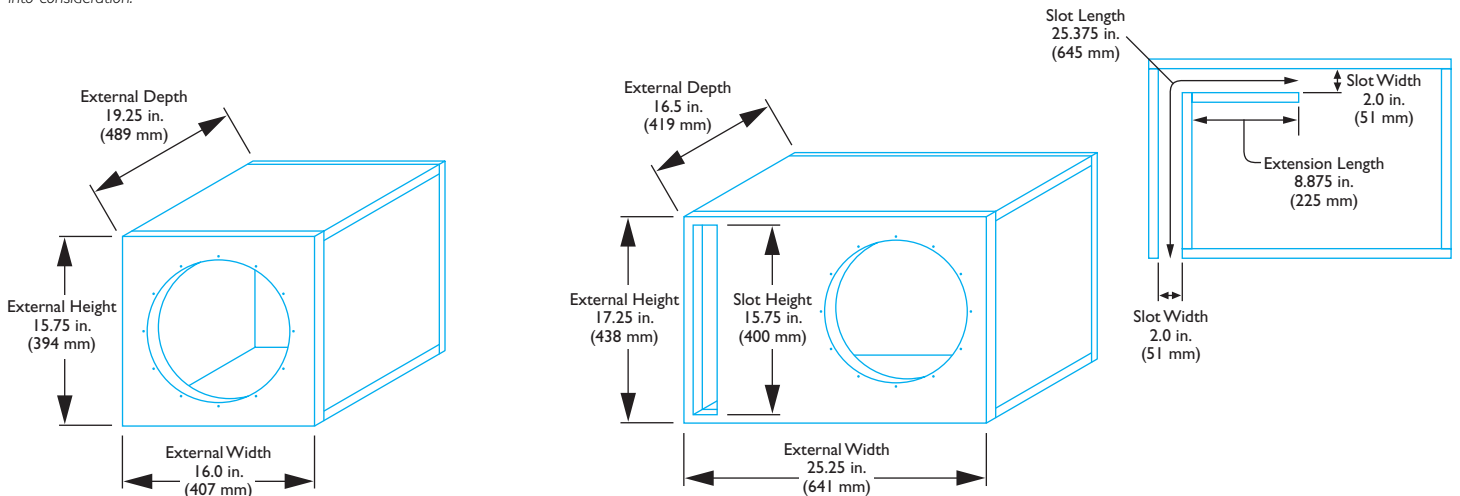

SEALED ENCLOSURE:

Recommended Net Volume: 1.875 cu. ft. (53.1 ltrs.)

Fc: 40.8 Hz **F3:** 36.3 Hz **Qtc:** 0.806

Front Baffle Thickness: 1 in. (25 mm)

Wall Thickness: 0.75 in. (19 mm)

PORTED ENCLOSURE:

Recommended Net Volume: 2.375 cu. ft. (67.3 ltrs.)

Recommended Port Tuning: 30 Hz

Port Type: "Slot" ports are recommended. See information below. The port recommendations listed below are derived through actual tests and measurements (not computer simulations).

Front Baffle Thickness: 1 in. (25 mm)

Wall Thickness: 0.75 in. (19 mm)

Input Sensitivity Setting Guide

What follows is a simple method for accurately setting the input sensitivity (commonly referred to as “gain”) of JL Audio subwoofer amplifiers. You will need the following equipment:

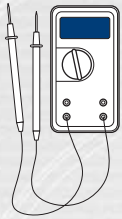

- AC Voltmeter (digital display type)
- A CD with a sine-wave test tone recorded at 0dB reference level in the frequency range to be amplified (40-50 Hz works well). Do not use attenuated test tones (-10dB, -20dB, etc.).

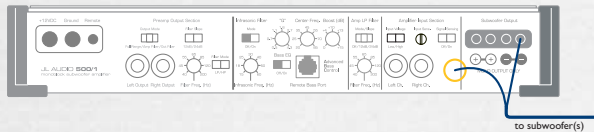
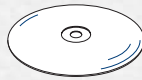

Step 1: Disconnect the W7(s) from the amplifier (It is only necessary to disconnect one wire).



Step 2: Turn “Off” all processing on the head unit and amplifier (bass / treble, loudness, EQ, etc.)

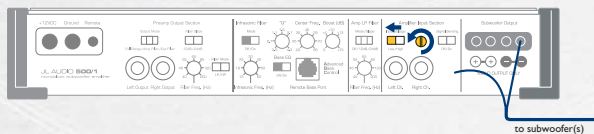

Step 3: Switch “Input Voltage” to “Low” and turn the “Input Sensitivity” control on the amplifier all the way down (full counter-clockwise).

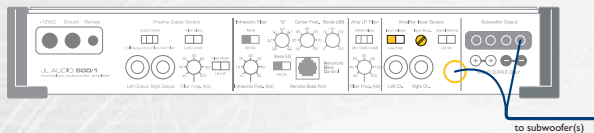

Step 4: Verify that you have disconnected the subwoofers from the amplifier. Then, set the head unit’s volume to 3/4 of full volume.



Step 5: Play a test track with a sine-wave (pure tone) between 40-50 Hz.

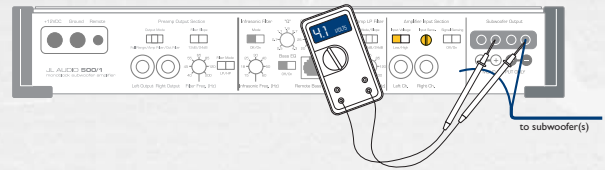

Step 6: Connect the AC voltmeter to the “Subwoofer Output” of the amplifier:

Step 7: Consult the list below and find the target output voltage based on the amplifier model used and the load impedance connected to each amplifier:

Target Output Voltage for JL Audio Amplifiers

- 250/1 connected to a 3Ω load----27.4 Volts
- 250/1 connected to a 1.5Ω load----19.4 Volts
- 500/1 connected to a 3Ω load----38.7 Volts
- 500/1 connected to a 1.5Ω load----27.4 Volts
- 1000/1 connected to a 3Ω load----54.7 Volts
- 1000/1 connected to a 1.5Ω load----38.7 Volts

If you are using another brand of amplifier, we recommend that you use an oscilloscope to verify the maximum unclipped output in the vehicle at realistic vehicle supply voltages.

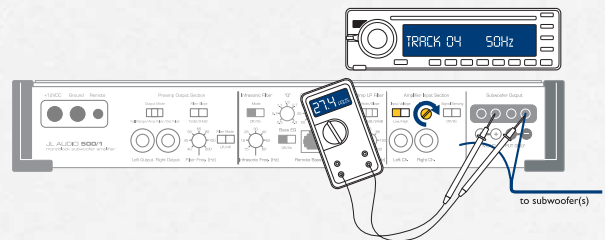

Step 8: Increase the “Input Sensitivity” control (clockwise) until the listed voltage is delivered. To level-match multiple subwoofer amps, set each one to the listed voltage. If excessive voltage is read with the control at minimum (full counter-clockwise), switch the “Input Voltage” to “High” and re-adjust.

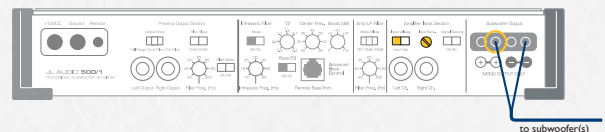

Step 9: Reduce the head unit’s volume and turn it off. Reconnect the subwoofers to the amplifier: