

CMU 18-447 INTRODUCTION TO COMPUTER ARCHITECTURE, SPRING 2014
HW 5: SIMD, VLIW, VIRTUAL MEMORY, AND CACHING

Instructor: Prof. Onur Mutlu

TAs: Rachata Ausavarungnirun, Varun Kohli, Xiao Bo Zhao, Paraj Tyle

Assigned: Wed., 3/11, 2014

Due: **Wed., 3/26, 2014 (Midnight)**

Handin: /afs/ece/class/ece447/handin/hw5

Please submit as ONE PDF: [andrewID].pdf

1 Virtual Memory [20 points]

An ISA supports an 8-bit, byte-addressable virtual address space. The corresponding physical memory has only 128 bytes. Each page contains 16 bytes. A simple, one-level translation scheme is used and the page table resides in physical memory. The initial contents of the frames of physical memory are shown below.

Frame Number	Frame Contents
0	Empty
1	Page 13
2	Page 5
3	Page 2
4	Empty
5	Page 0
6	Empty
7	Page Table

A three-entry translation lookaside buffer that uses Least Recently-Used (LRU) replacement is added to this system. Initially, this TLB contains the entries for pages 0, 2, and 13. For the following sequence of references, put a circle around those that generate a TLB hit and put a rectangle around those that generate a page fault. What is the hit rate of the TLB for this sequence of references? (Note: LRU policy is used to select pages for replacement in physical memory.)

References (to pages): 0, 13, 5, 2, 14, 14, 13, 6, 6, 13, 15, 14, 15, 13, 4, 3.

- (a) At the end of this sequence, what three entries are contained in the TLB?
- (b) What are the contents of the 8 physical frames?

2 Page Table Bits [10 points]

- (a) What is the purpose of the “reference” or “accessed” bit in a page table entry?
- (b) Describe what you would do if you did not have a reference bit in the PTE. Justify your reasoning and/or design choice.
- (c) What is the purpose of the dirty or modified bit in a page table entry?
- (d) Describe what you would do if you did not have a modified bit in the PTE. Justify your reasoning and/or design choice.

3 Caching [15 points]

Below, we have given you four different sequences of addresses generated by a program running on a processor with a data cache. Cache hit ratio for each sequence is also shown below. Assuming that the cache is initially empty at the beginning of each sequence, find out the following parameters of the processor's data cache:

- Associativity (1, 2 or 4 ways)
- Block size (1, 2, 4, 8, 16, or 32 bytes)
- Total cache size (256 B, or 512 B)
- Replacement policy (LRU or FIFO)

Assumptions: all memory accesses are one byte accesses. All addresses are byte addresses.

Sequence No.	Address Sequence	Hit Ratio
1	0, 2, 4, 8, 16, 32	0.33
2	0, 512, 1024, 1536, 2048, 1536, 1024, 512, 0	0.33
3	0, 64, 128, 256, 512, 256, 128, 64, 0	0.33
4	0, 512, 1024, 0, 1536, 0, 2048, 512	0.25

4 Magic-RAM [25 points]

Assume you developed the next greatest memory technology, MagicRAM. A MagicRAM cell is non-volatile. The access latency of a MagicRAM cell is 2 times that of an SRAM cell but the same as that of a DRAM cell. The read/write energy of MagicRAM is similar to the read/write energy of DRAM. The cost of MagicRAM is similar to that of DRAM. MagicRAM has higher density than DRAM. MagicRAM has one shortcoming, however: a MagicRAM cell stops functioning after 2000 writes are performed to the cell.

(a) Is there an advantage of MagicRAM over DRAM other than its density? (Please do not repeat what is stated in the above paragraph.) Circle one: **YES** **NO**

Explain.

(b) Is there an advantage of MagicRAM over SRAM? Circle one: **YES** **NO**

Explain.

(c) Assume you have a system that has a 64KB L1 cache made of SRAM, a 12MB L2 cache made of SRAM, and 4GB main memory made of DRAM.

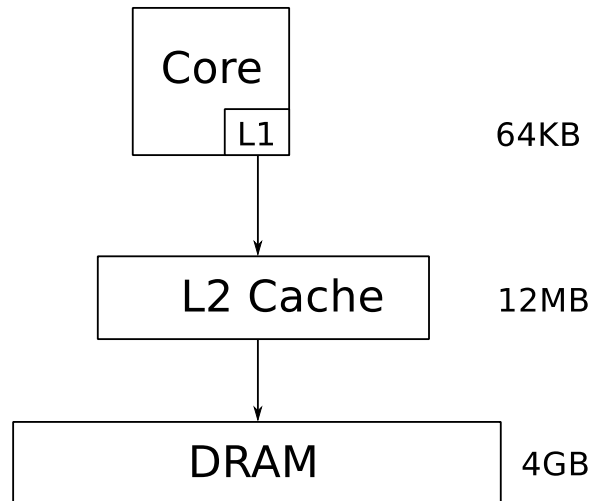

Assume you have complete design freedom and add structures to overcome the shortcoming of MagicRAM. You will be able to propose a way to reduce/overcome the shortcoming of MagicRAM (note that you can design the hierarchy in any way you like, but cannot change MagicRAM itself).

Does it makes sense to add MagicRAM anywhere in this memory hierarchy given that you can potentially reduce its shortcoming? Circle one: **YES** **NO**

If so, where would you place MagicRAM? **Depict in the figure above clearly** and describe why you made this choice.

If not, why not? Explain below clearly and methodically.

- (d) Propose a way to reduce/overcome the shortcoming of MagicRAM by modifying the given memory hierarchy. Be clear in your explanations and illustrate with drawings to aid understanding.

Explanation: